



# **CEDARBRAE'S GRADE 8 COURSE AND PROGRAM INFORMATION**

**CEDARBRAE**  
**COLLEGIATE**  
**INSTITUTE**



**Hic Patet In Genius Campus - "Here is a place where  
talent thrives"**

## Table of Contents

	Page
<b><u>Grade 9 Elective Courses</u></b>	
• Arts (Drama, Music, Visual Arts)	1 & 2
• Business	3 & 4
• Technological Studies	5
• Family Studies	6
• Guidance – Skills for Success in Secondary School	7
• Special Education – GLE – Learning Strategies	8 & 9
<b><u>Grade 9 Core Subjects and Special Programs</u></b>	
• English and English as a Second Language	10 & 11
• Geography	12
• Health and Physical Education	13
• International Languages	14 & 15
• Math	16
• Science	17
<b><u>Special Program</u></b>	
• C <i>Ci</i> STEM (Central Student Interest Program)	18 & 19
<b>Certificates of Achievement</b>	<b>20 &amp; 21</b>
<b>Diploma Requirements</b>	<b>22</b>

For more information about Cedarbrae visit  
<https://schoolweb.tdsb.on.ca/cedarbraeci>

# GRADE 9 ELECTIVE COURSE DESCRIPTIONS



## THE ARTS



### **DRAMATIC ARTS – ADA101 – OPEN**

This course emphasizes the active exploration of dramatic forms and techniques, using material from a wide range of authors, genres, and cultures. Students will construct, discuss, perform, and analyze drama, and then reflect on the experiences to develop an understanding of themselves, the art form and the world around them.

### **INSTRUMENTAL MUSIC (BAND/WOODWINDS/BRASS) – AMI101 – OPEN**

Students will focus their work on the various aspects of musical performance through the study of a woodwind, brass or percussion instrument in a band setting. This course is for students who already play an instrument.

### **MUSIC – KEYBOARD MUSIC – AMK101 – OPEN**

Students will focus on the skills specific to the piano keyboard and will learn authentic repertoire.

### **MUSIC – VOCAL – AMV101 – OPEN**

This course is designed for students wishing to learn about singing and participate in a choir setting.

### **FIRST NATIONS, MÉTIS, AND INUIT STUDIES (Visual Arts)**

#### **Expressions of First Nations, Métis, and Inuit Cultures – NAC101 – OPEN**

This course will explore a variety of contemporary and traditional First Nations, Métis, and Inuit art forms. This course offers an overview of visual arts as a foundation for further study. Students will become familiar with the elements and principles of design and the expressive qualities of various materials. They will create art works to express their own ideas and understanding of Aboriginal identity, relationships, and sovereignty by using a range of media, processes, techniques, and styles.

#### **ARTS VISUELS - AVI105 - Immersion French - OPEN**

##### **This course is for French Immersion students.**

This course offers an overview of visual arts as a foundation for further study. Students will become familiar with the elements and principles of design and the expressive qualities of various materials through working with a range of materials, processes, techniques, and styles. They will learn and use methods of analysis and criticism and will study the characteristics of particular historical art periods and a selection of Canadian art and the art of other cultures.

#### **ARTS VISUELS - AVI104 - Extended French - OPEN**

##### **This course is for Extended French students.**

This course offers an overview of visual arts as a foundation for further study. Students will become familiar with the elements and principles of design and the expressive qualities of various materials through working with a range of materials, processes, techniques, and styles. They will learn and use methods of analysis and criticism and will study the characteristics of particular historical art periods and a selection of Canadian art and the art of other cultures.

# VISUAL & PERFORMING ARTS

**GRADE 9 REQUIREMENT IS ONE OF:  
BAND, DRAMA, KEYBOARD,  
VISUAL ART, VOCAL**



## BAND

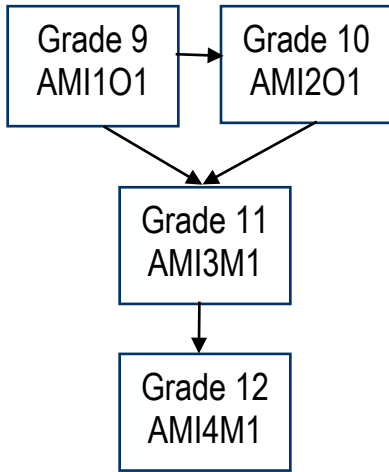

## DRAMA

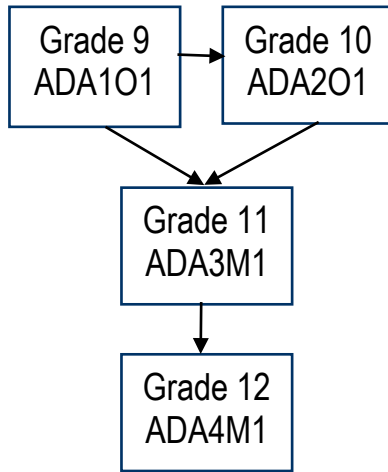

## FILM

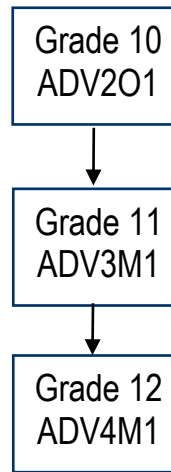

## GUITAR

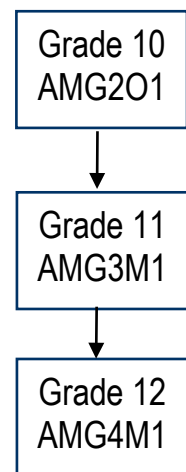

## VOCAL

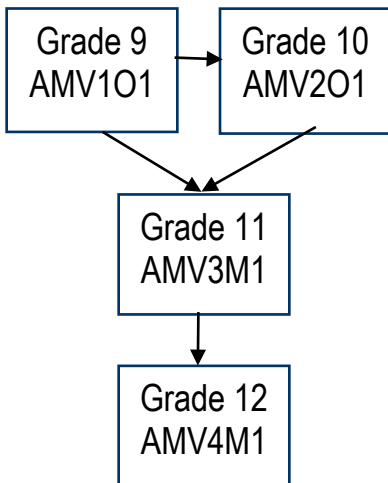

## KEYBOARD MUSIC

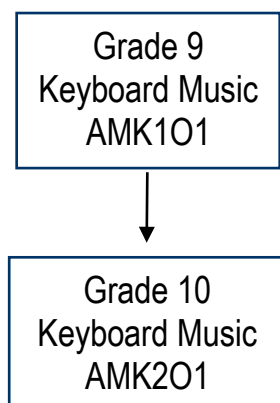

## VISUAL ART

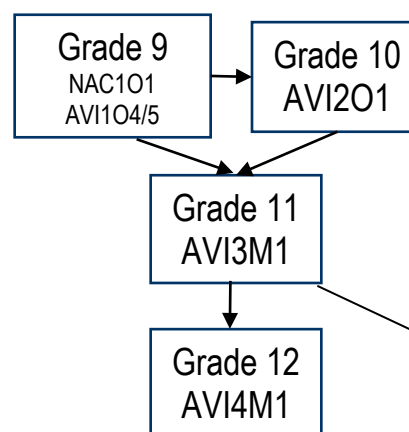

## SPECIAL FOCUS ART

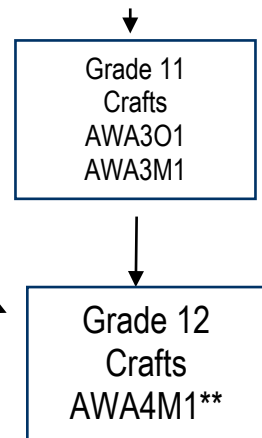

\*\* Requires AVI3M1 OR AWA3M1

## LANGUAGE OPTIONS

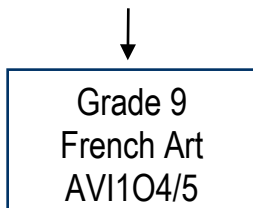



# BUSINESS STUDIES



## **Building the Entrepreneurial Mindset, Grade 9, Open (BEM10)**

In this course, students will learn what makes an entrepreneur thrive and the skills required to succeed in today's business environment. Students will begin to develop their own entrepreneurial mindset, and learn why it's important to take initiative, adapt to change, find creative solutions, and understand the financial considerations of entrepreneurship. This hands-on course will use business software and applications to help students plan and develop their entrepreneurial ideas and learn how to present them to a target audience. Throughout the course, students will enhance their communications skills as well as develop and refine their project management skills, including goal setting, time management, and networking.

## **BUILDING THE ENTREPRENEURIAL MINDSET**

### **Course Codes:**

- English -BEM101
- ESL - BEM108
- Extended French – BEM104
- French Immersion – BEM105
- CCi STEM - BEM10P

## Business Studies Flow Chart

**BEM10**  
Building the Entrepreneurial Mindset  
Grade 9 Open

**BEP20**  
Launching and Leading a Business  
Grade 10 Open

**BAF3M**  
Financial Accounting Fundamentals  
Grade 11  
  
College/University

**BAI3E**  
Accounting Essentials

Any University, University/College or College Preparation course in Business Studies or Canadian and World Studies.

**BDI3C**  
Entrepreneurship The Venture  
  
Grade 11  
College

**BMI3C**  
Marketing Goods and Services  
  
Grade 11  
College

**BAT4M**  
Financial Accounting Principles  
Grade 12  
College/University

**IDC4U**  
Financial Securities  
Grade 12  
University (IDCFIN)

**BOH4M**  
Business Leadership: Management Fundamentals  
Grade 12  
College/University

**BBB4M**  
International Business Fundamentals  
Grade 12  
College/University

**IDC4U**  
Sports and Entertainment Marketing  
  
Grade 12  
University (IDCSPO)

*\*Earn a Business Certificate by completing 5 Credits in Business Studies from the choices above!*

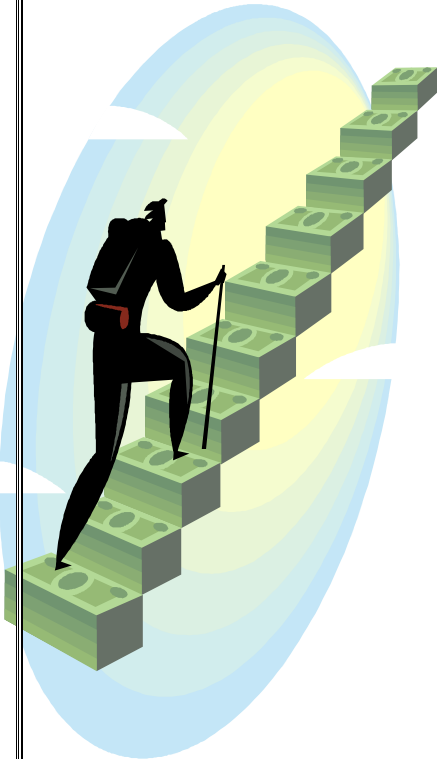



## TECHNOLOGICAL STUDIES CURRICULUM INFORMATION GRADE 9



### Technology and the Skilled Trades, Grade 9, Open (TAS10)

This hands-on course enables students to further explore the engineering design process and develop other technological knowledge and skills introduced in earlier grades. Students will design and safely create prototypes, products, and/or services, working with tools and technologies from various industries. As students develop their projects to address real-life problems, they will apply technological concepts such as precision measurement, as well as health and safety standards. Students will begin to explore job skills programs and education and training pathways, including skilled trades, that can lead to a variety of careers.

During their stay in TECHNOLOGICAL STUDIES, we offer the students as much variety as possible.

SUBJECT AREA	BRIEF SAMPLE OUTLINE
<b>TRANSPORTATION</b>	<ul style="list-style-type: none"> <li>- Acquire knowledge, skills, and values in a variety of learning experiences in the fields of: Transportation - air, land, and sea</li> <li>- Environmental concerns</li> <li>- Impact on society</li> </ul>
<b>DRAFTING</b>	<ul style="list-style-type: none"> <li>-Acquire knowledge, skills, and values in a variety of learning experiences in the field of drafting line work</li> <li>-Fundamentals of multi -view drawings</li> <li>-Using traditional as well as computer assisted drawings (CAD)</li> </ul>
<b>COMMUNICATIONS</b>	<ul style="list-style-type: none"> <li>-Acquire knowledge, skills, and values in a variety of learning experiences in the field of communications</li> <li>-Audio, video, photographic and computer graphics use as it applies to these areas</li> </ul>
<b>WOODWORKING</b>	<ul style="list-style-type: none"> <li>-Acquire knowledge, skills, and values in a variety of learning experiences in the field of woodworking</li> <li>-Safe use of hand and power tools, wood identification, basic cabinet making joints, and work on activity-based projects</li> </ul>
<b>NOTE</b>	<p>Classes in grade nine <u>may</u> take all the above subjects - however not every student will be exposed to all areas; every effort is made to expose the student to as many areas as possible. All technology areas have as a key component; a project or projects that involve plenty of activity, problem solving and teamwork. Evaluation of students is based on their practical work (projects), as well as their theory work (tests, assignments, presentations). The student's mark reflects their complete grade nine technology course.</p>



## SOCIAL SCIENCE AND THE HUMANITIES



### EXPLORING FAMILY STUDIES - HIF101 – OPEN - For English as a Second Language students we offer HIF208

This course explores, within the context of families, some of the fundamental challenges people face: how to meet basic needs, how to relate to others, how to manage resources, and how to become responsible members of society. Students will explore adolescent development and will have opportunities to develop interpersonal, decision-making, and practical skills related to daily life. They will learn about the diverse ways in which families function in Canada and will use research skills as they explore topics related to individual and family needs and resources.

### Exploring Family Studies

HIF101/HIF208

Grade 9/10

Open



**WHO ARE YOU?** Do you have the knowledge and skills that are needed to make the transition to adulthood? Learn some practical skills related to daily family living.

Topics to be covered will include:

- ◆ Who Am I ?
- ◆ Function of the Family
- ◆ Diversity of Families
- ◆ Managing our resources—time and money
- ◆ Introduction to research skills





## Guidance – Skills for Success in Secondary School

**Skills for Success in Secondary School – GLS101 – OPEN - For English as a Second Language student we offer GLS208**

**This Course is for students who do not have an IEP (Individual Education Plan)**

This course focuses on learning strategies to help students become better, more independent learners. Students will learn how to develop and apply literacy and numeracy skills, personal management skills, and interpersonal and teamwork skills to improve their learning and achievement in school, the workplace and the community. The course helps students build confidence and motivation to pursue opportunities for success in secondary school and beyond.

## Guidance and Career Education



As students look forward to beginning high school, it's hard to believe that in just a few years they will be taking another big step into the world of work. After graduation, students may be heading to apprenticeship, college, university, or directly to work, and Cedarbrae has a comprehensive program to help each student make career and educational plans. Additionally, the Cedarbrae Student Services Webpage provides online resources to assist students with career and educational planning. (<https://schoolweb.tdsb.on.ca/cedarbraeci/Guidance>)

Counsellors and teachers monitor student success and assist students as they make pathway choices. Students may also make appointments with counsellors for career and educational counseling.

Whether or not a student has a specific career in mind, it is important to select both compulsory and optional courses carefully so that requirements for post-secondary education or training are met. Cedarbrae offers a wide variety of optional courses which can help students discover interests and strengths and develop skills leading to career choices. All students in Grade 10 are required to successfully complete the ½ credit Career Studies course.



## SPECIAL EDUCATION – Learning Strategies

### LEARNING STRATEGIES – GLE109 – OPEN

This course explores learning strategies and helps students become better, more independent learners while increasing their personal management skills, both in school and in other contexts. Students will learn how to develop and apply a range of strategies to improve their learning and achievement, particularly their literacy, numeracy, communication, and planning skills. This course will increase students' confidence, motivation, and ability to learn.

**Prerequisite: Students must have an Individual Education Plan and recommendation of Principal**



## Special Education

Students who have an Individual Education Plan are considered part of Cedarbrae's Special Education Department. The Special Education department offers supports, accommodations and strategies to help facilitate student success.

### **Learning Strategies Course - GLE1/2/3/40 (students who have an IEP only)**

GLE classes are split into grade 9/10 and grade 11/12. These courses are designed to be smaller in size and give students a chance to complete work from their other classes. The teacher can help students with academic support when necessary and works with students on learning skills for success in GLE. There is no exam in the course, but there are a series of assignments and a course culminating at the end. This course is a nice balance for students to complete course work, while getting academic support for other classes at the same time.

Course curriculum includes strategies that help develop skills students need to be successful. Determining your learning style, organizational skills, goal setting, test-taking and memorization strategies, time management skills, self-advocacy, and improving basic literacy and numeracy skills are some of the key points covered in these courses.

## Special Education

### **RESOURCE ROOM – 319 (every student in the school has access to this room)**

The resource room is a place for students to receive one on one support for any of their courses. They can also receive computer and printer access, a quiet space for working or a place to write a test/quiz. Students advocate for themselves and ask their teachers to come up to the room. Students can come for 15-20 minutes or the entire period, depending on what type of academic support they are looking for.

The resource room has 10 computers available for student use and a printer. The room also has a chrome book cart that allows IEP students to have technology with them for a particular class if needed. They need to speak with the special education teachers to discuss how to access the computers.

All students in the school also have access to the Read and Write program. This is a computer program that allows speech to text assistance, text to speech assistance, a dictionary, reading text feature and so much more. Ask your child to show you this amazing program. This program helps lessen barriers for written expression, reading comprehension, word decoding or recognition that many of our student's experience allowing them more opportunity to demonstrate their learning.





# ENGLISH

## ENGLISH – ENL1W1 - De-streamed

This course enables students to continue to develop and consolidate the foundational knowledge and skills that they need for reading, writing, and oral and visual communication. Throughout the course, students will continue to enhance their media literacy and critical literacy skills, and to develop and apply transferable skills, including digital literacy. Students will also make connections to their lived experiences and to society and increase their understanding of the importance of language and literacy across the curriculum.

The English department is constantly updating the selection of novels used in the courses to include a wide variety of genres and perspectives. Each course explores poignant themes such as Bildungsroman, dystopia, and Indigenous perspectives. The Creative Writing course has returned to offer students the opportunity to explore storytelling with short stories, poetry, and screenplay writing. More interactive activities and guest speakers are also returning to the courses with new ways of using technology correctly to enhance learning.

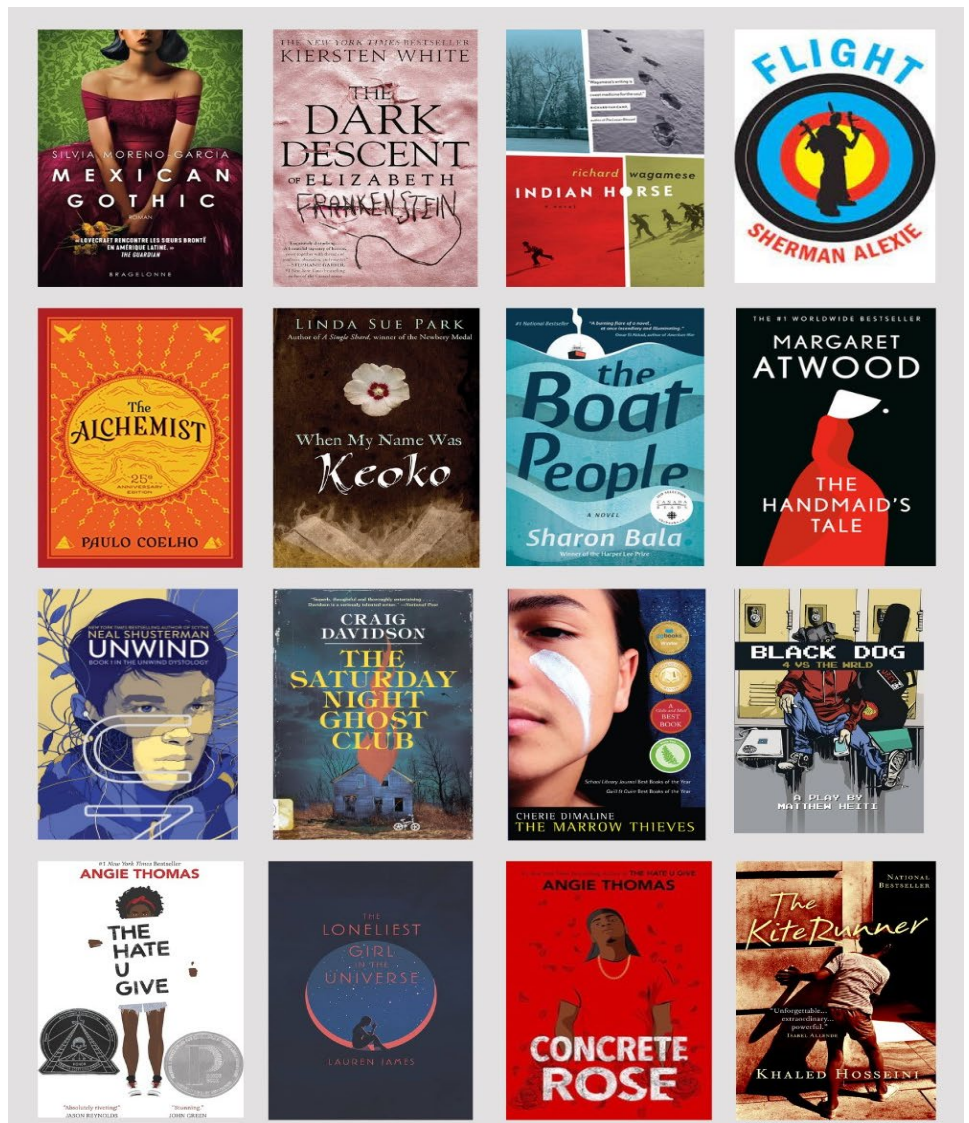



## **ENGLISH AS A SECOND LANGUAGE**

At Cedarbrae, we offer 5 levels of ESL in preparation for the regular stream of English classes. Students will be placed at the level suggested by the TDSB Assessment Centre upon entry to the school.

We also have LEAP (Literacy Enrichment Academic Program). LEAP is an accelerated program for students who have recently arrived in Ontario who have limited prior schooling

Students have the opportunity to take ESL Geography (CGC1D8), ESL Information & Communication Technology and Business (BTT1O8), ESL Skills for Success in Secondary School (GLS1O8), and ESL Exploring Family Studies (HIF2O8). These courses will help strengthen the student's oral skills, confidence, and creativity.

Students and parents also have access to settlement workers in the school who help families transition and acclimatization to a new environment.

# GEOGRAPHY DEPARTMENT



## Grade 9

### **GEOGRAPHY OF CANADA (CGC1W)**

(De-streamed, Extended French, French Immersion & ESL Options Available)

#### **Issues in Canadian Geography, Grade 9, De-streamed (CGC1W)**

Students will explore relationships within and between Canada's natural and human systems and how they interconnect with other parts of the world. Students will also examine environmental and economic issues, and their impact related to topics such as natural resources and industries, careers, land use and responsible development, and sustainability. In addition, students will understand the connections that diverse communities and individuals have with the physical environment and each other throughout Canada, including First Nations, Métis, and Inuit perspectives. Students will apply geographic thinking, use the geographic inquiry process, and use geospatial technologies throughout their investigations.



# Health & Physical Education



**PHYS. ED A COURSE FOR THE PEOPLE-- BY THE PEOPLE**

## CHOOSE YOUR ACTIVITIES

<b>TERRITORY GAMES</b>	<b>NET / WALL GAMES</b>	<b>TARGET GAMES</b>	<b>STRIKING / FIELDING GAMES</b>	<b>OTHER</b>
Basketball	Badminton	Archery	Baseball	Pool
Football	Volleyball	Bocce	Softball	Dodgeball
European handball	Pickleball	Curling	Cricket	Fitness
Hockey	Table tennis	Disc golf	Kick-ball	Track & Field
Lacrosse	Spikeball	Disc slam		Yoga
Soccer	Tennis	Horse shoes		Meditation/ Mindfulness
Rugby				
Ultimate				



### Healthy Active Living Education, Grade 9, Open (PPL10 offered in English and French)

This course equips students with the knowledge and skills they need to make healthy choices now and lead healthy, active lives in the future. Through participation in a wide range of physical activities, students develop knowledge and skills related to movement competence and personal fitness that provide a foundation for active living. Students also acquire an understanding of the factors and skills that contribute to healthy development and learn how their own well-being is affected by, and affects, the world around them. Students build their sense of self, learn to interact positively with others, and develop their ability to think critically and creatively.

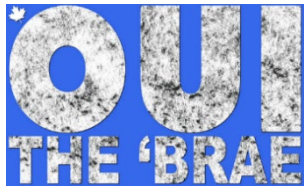

## **International Languages (French & Spanish)**

Unlock your language power and develop lifelong language learning skills with our French and Spanish courses. Our goal is to inspire our learners to fall in love with language learning through the use of games and modern teaching techniques that move away from traditional grammar and conjugation. We are proud to have built the largest Spanish department in the TDSB and look forward to welcoming you and your children to Braeville next year. Oui the Brae! Si da Brae!

### **GRADE 9 FRENCH AS A SECOND LANGUAGE COURSES**

#### **CORE FRENCH - FSF1D1 - ACADEMIC**

This course provides opportunities for students to communicate and interact in French with increasing independence, with a focus on familiar topics related to their daily lives. Students will continue to develop language knowledge and skills by using language-learning strategies introduced in the elementary Core French program and will apply creative and critical thinking skills in various ways. They will also enhance their understanding and appreciation of diverse French-speaking communities and will develop the skills necessary to become life-long language learners. **Prerequisite:** Minimum of 600 hours of elementary Core French instruction, or equivalent

**CORE FRENCH – INTRODUCTORY/BEGINNER - FSF1O1 – OPEN** This is an introductory course for students who have little or no knowledge of French or who have not accumulated the minimum of 600 hours of elementary Core French instruction. Students will begin to understand and speak French in guided and structured interactive settings and will develop fundamental communication skills through discussing situations and issues that are relevant to their daily lives. Throughout the course, students will develop their awareness of diverse French-speaking communities in Canada and acquire an understanding and appreciation of these communities. They will also develop a variety of skills necessary to become life-long language learners.

**Prerequisite:** None

#### **IMMERSION FRENCH - FIF1D5 - ACADEMIC**

This course provides opportunities for students to speak and interact in French independently in a variety of real-life and personally relevant contexts. Students will develop their ability to communicate in French with confidence by using language-learning strategies introduced in the elementary French Immersion program. Students will enhance their knowledge of the language through the study of French-Canadian literature. They will also continue to increase their understanding and appreciation of diverse French-speaking communities and to develop the skills necessary to become life-long language learners.

**Prerequisite:** Minimum of 3800 hours of instruction in elementary French Immersion, or equivalent

#### **EXTENDED FRENCH - FEF1D4 - ACADEMIC**

This course provides opportunities for students to speak and interact in French in a variety of real-life and personally relevant contexts. Students will continue to use language-learning strategies introduced in the elementary Extended French program. They will develop their creative and critical thinking skills, through independently responding to and interacting with a variety of oral and written texts and will continue to enhance their understanding and appreciation of diverse French-speaking communities. They will also develop the skills necessary to become life-long language learners.

**Prerequisite:** Minimum of 1260 hours of instruction in elementary Extended French, or equivalent



## GRADE 9 COURSES OFFERED IN FRENCH IMMERSION AND EXTENDED FRENCH

<b><i>COURSE TITLE</i></b>	<b><i>EXTENDED COURSES</i></b>	<b><i>IMMERSION COURSES</i></b>
FRANÇAIS (IMMERSION or EXTENDED)	<b>FRENCH</b> <i>FEF1D4</i>	<b>FRENCH</b> <i>FIF1D5</i>
ENJEUX GEOGRAPHIQUES DU CANADA	<b>FRENCH</b> <i>CGC1D4</i>	<b>FRENCH</b> <i>CGC1D5</i>
ÉDUCATION PHYSIQUE ET HYGIÈNE (FILLES)	<b>FRENCH</b> <i>PPL10J</i>	<b>FRENCH</b> <i>PPL10G</i>
ÉDUCATION PHYSIQUE ET HYGIÈNE (GARÇONS)	<b>FRENCH</b> <i>PPL10U</i>	<b>FRENCH</b> <i>PPL10Q</i>
ÉDUCATION PHYSIQUE ET HYGIÈNE (FILLES & GARÇONS)	<b>FRENCH</b> <i>PPL10L</i>	<b>FRENCH</b> <i>PPL10K</i>
MATHÉMATIQUES	<b>ENGLISH</b> <i>MTH1W1</i>	<b>FRENCH</b> <i>MTH1W5</i>
SCIENCE	<b>ENGLISH</b> <i>SNC1W1</i>	<b>FRENCH - SNC1W5</b> <b>ENGLISH - SNC1W1</b>
VISUAL ART (IMMERSION or EXTENDED)	<b>FRENCH - AVI104</b> <b>ENGLISH – NAC101</b>	<b>FRENCH - AVI105</b> <b>ENGLISH – NAC101</b>
BUSINESS (IMMERSION or EXTENDED)	<b>FRENCH – BEM104</b> <b>ENGLISH – BEM101</b>	<b>FRENCH – BEM105</b> <b>ENGLISH – BEM101</b>





If you love the natural world and want to understand your place within it, Cedarbrae Science has a lot to offer. Push back boundaries of the unknown and develop your passion for science with us. Our programming will expand your knowledge and interests and help you learn about your place in nature.

With our enthusiastic teachers, Cedarbrae Science is a great place to learn. We have eight fully equipped labs where students investigate principles of biology, chemistry, physics and earth and space science. Experiment in areas of density, microscopy, electric circuits, dissections, bacterial culture, chemical reactions, optics, kinematics and more.

Make the most of your time with us by being involved in academic life. The Cedarbrae Science department offers multiple opportunities to engage in academic contests, field trips, clubs, and mentorship programs.

We offer grade nine and ten courses in French for students in the Immersion program. Furthermore, our ever-expanding STEM pathway encourages innovation in science at all levels. By applying for this program, you gain the opportunity to explore STEM the way you want through our math, science, technology, or kinesiology pathways.

In recognition of our students' commitment to our department, we offer two Science Certificates upon graduation. Regular requirements are for those students who have completed five senior science courses. Honours requirements are for students who have completed six or more senior science courses. The future of science and technology has never been so exciting or so promising. We invite you to be part of this exciting journey of discovery.

**SCIENCE - SNC1W1 – DE-STREAMED**

This course enables students to develop their understanding of concepts related to biology, chemistry, physics, and Earth and space science, and to relate science to technology, society, and the environment. Throughout the course, students will develop and refine their STEM skills as they use scientific research, scientific experimentation, and engineering design processes to investigate concepts and apply their knowledge in situations that are relevant to their lives and communities. Students will continue to develop transferable skills as they become scientifically literate global citizens.

**SCIENCE - SNC1W5 – DE-STREAMED - This course is for French Immersion Students.**

This course enables students to develop their understanding of concepts related to biology, chemistry, physics, and Earth and space science, and to relate science to technology, society, and the environment. Throughout the course, students will develop and refine their STEM skills as they use scientific research, scientific experimentation, and engineering design processes to investigate concepts and apply their knowledge in situations that are relevant to their lives and communities. Students will continue to develop transferable skills as they become scientifically literate global citizens.



## CEDARBRAE COLLEGIATE *INNOVATION* STEM (CCi STEM)

At Cedarbrae we are passionate about STEM education, and we want YOU to be a part of Cedarbrae Collegiate *innovation*! By applying for our program, you gain an opportunity to explore STEM the way you want through our math, science, technology, or kinesiology pathways. In grade nine you will have the unique opportunity of completing your science, English, and business credits in a combined three course package working collaboratively on projects that involve all three subjects.

Throughout your 4 years of the CCi program you will explore learning opportunities that include:

- Field trips
- Problem based learning
- Industry expert guest speakers
- Post secondary outreach
- Cross curricular classes
- Technology embedded learning
- Game based learning

Upon completion of the program, students will be able to investigate the world, weigh perspectives, communicate ideas, take action and apply disciplinary and interdisciplinary expertise in school and beyond.

### Required Courses

Grade 9	Grade 10	Grade 11	Grade 12
ENL1WP	ENG2DP	<b>Select at least one Grade 11 course in:</b>	HSE4MP
SNC1WP	SNC2DP	Computer Science	<b>Select at least one Grade 12 course in:</b>
BEM1OP	ICD2O1	Science	Computer Science
		Technology	Kinesiology
			Science
			Technology

# INNOVATORS WANTED

## CCi Student Pathway

Your roadmap to innovation

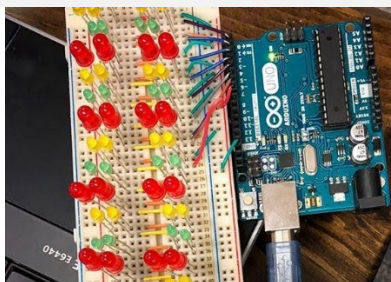
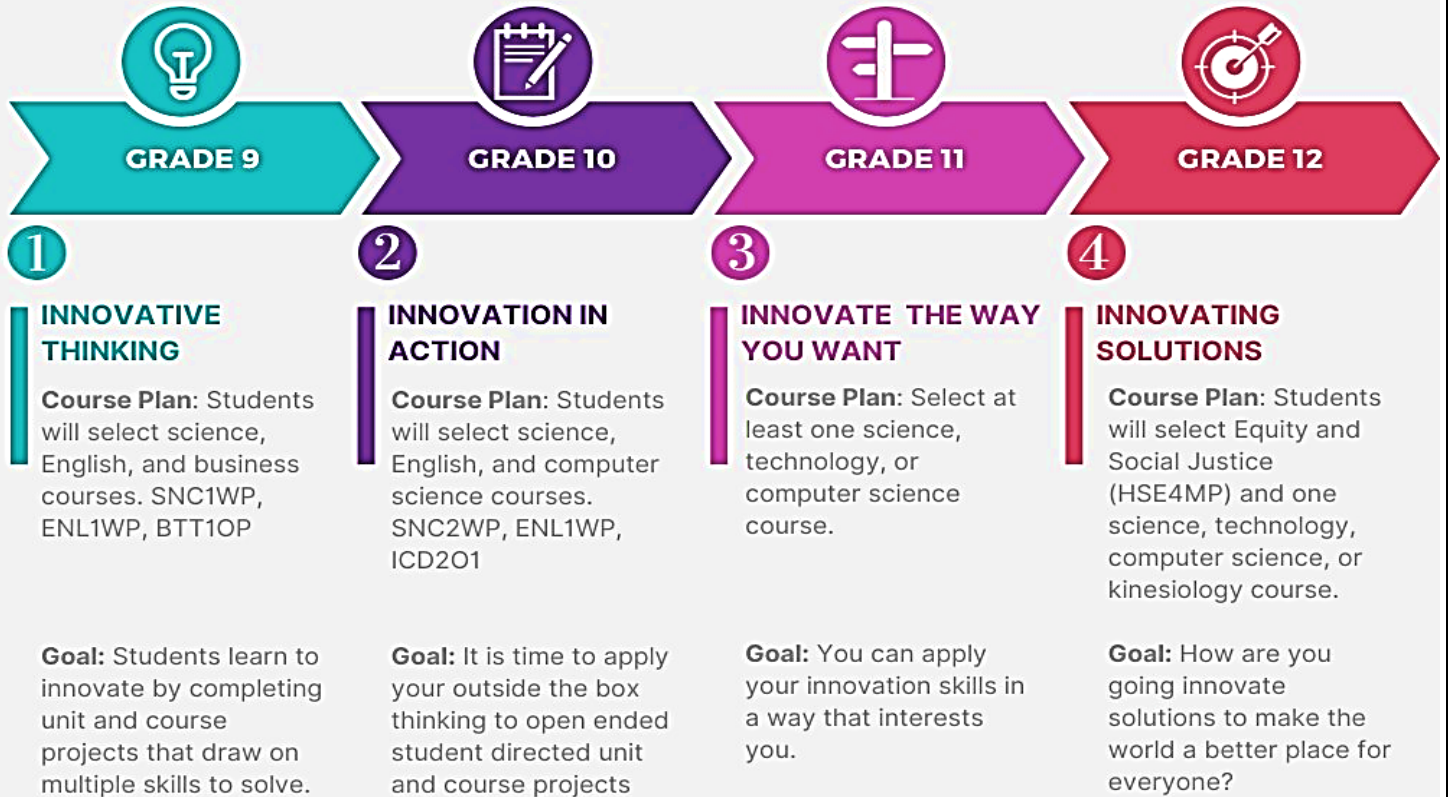

# CERTIFICATES OF ACHIEVEMENT OFFERED AT CEDARBRAE COLLEGIATE



## VISUAL ARTS CERTIFICATE

Cedarbrae is proud to offer courses that cover a variety of traditional and digital media techniques. The **Visual Arts Certificate** is awarded to students who have completed **four (4)** or more courses in AVI, NAC, and AWA.



## BUSINESS STUDIES CERTIFICATE

Students who have earned a minimum of **five (5)** credits in Business Studies including credits assigned from grade 9 will earn the **Business Studies Certificate**. Course codes that begin with the letter 'B' will be counted for this certificate along with one IDC4 course in Sports and Entertainment Marketing or Financial Securities.



## EXTENDED FRENCH AND IMMERSION FRENCH

**Certificate of Bilingual Studies in Extended French** will be awarded to students who earn the Ontario Secondary School Diploma and complete **seven (7)** credits in Extended French including 4 "FEF" credits grade 9 to 12.

**Certificate of Bilingual Studies in French Immersion** will be awarded to students who earn the Ontario Secondary School Diploma and complete **ten (10)** credits in Immersion French including 4 "FIF" credits grade 9 to 12.



**Honours Certificate of Bilingual Studies in Extended French** will be awarded to students who earn the Ontario Secondary School Diploma and complete **eight (8)** or more credits in Extended French including 4 "FEF" credits grade 9 to 12.

**Honours Certificate of Bilingual Studies in French Immersion** will be awarded to students who earn the Ontario Secondary School Diploma and complete **eleven (11)** or more credits in Immersion French including 4 "FIF" credits grade 9 to 12.



## PERFORMING ARTS CERTIFICATE (Music, Drama, and Film)



Students who have successfully completed a minimum of **four (4)** credits in music, and/or drama (including film) will be awarded a **Performing Arts Certificate**. Involvement in extracurricular performance will count as one (1) credit. This will recognize their commitment and background in the area of performing arts. The certificate could be of benefit to students when applying for employment or enrolment in post-secondary arts education. (AMI, AMG, AMK, AMQ, AMV, ADA, ADV)

## PHYSICAL AND HEALTH EDUCATION CERTIFICATE



The **Physical and Health Education Certificate** is awarded to students who have completed a combination of **four (4)** courses in PPL and PAF plus **one (1)** course in PSK4U (Introduction to Kinesiology) or PLF4M (Recreation and Fitness Leadership)

## SENIOR SCIENCE CERTIFICATE



Students who have successfully completed **five (5)** senior courses in science will earn a **Senior Science Certificate**. Students that have successfully completed **six (6)** or more senior science courses will earn an **Honours Senior Science Certificate**.

## SOCIAL SCIENCE CERTIFICATE

Students who have earned a minimum of **seven (7)** credits in Family Studies, Geography, and/or History including credits assigned from Grade Nine may earn a **Social Science Certificate**. Students that earn **nine (9)** credits in Family Studies, Geography, and /or History will be eligible to receive an **Honours Social Science Certificate**.



## TECHNOLOGICAL STUDIES CERTIFICATE



Students who have earned a minimum of **five (5)** credits in technological studies will be awarded the **Technological Studies Certificate**. Course codes that begin with the letter 'T' will be counted for this certificate. This certificate should be of benefit to students seeking employment or applying for admission to post-secondary programs in technical areas.



# What do you need to graduate?

Students must earn the following compulsory credits to obtain the Ontario Secondary School Diploma:

- 4 credits in English\*
- 3 credits in mathematics
- 2 credits in science
- 1 credit in Canadian history
- 1 credit in Canadian geography
- 1 credit in arts
- 1 credit in health and physical education
- 1 credit in French as a second language
- 0.5 credit in career studies
- 0.5 credit in civics

➤ **Plus, one credit from each of the following groups:**

**GROUP 1** - 1 additional credit in English, or French as a second language\*\* or a Native language, or a classical or an international language or social sciences and the humanities, or Canadian and world studies, or guidance and career education, or cooperative education\*\*\*

**GROUP 2** - 1 additional credit in health and physical education, or the arts, or business studies, or French as a second language\*\* or guidance and career education, or cooperative education\*\*\*

**GROUP 3** - 1 additional credit in science, or technological education, or French as a second language\*\* or computer studies, or cooperative education\*\*\*

➤ **A total of 18 compulsory credits**

**In addition to the 18 compulsory credits, students must complete:**

- **12** optional credits
- **40** hours of community involvement activities
- **2** online e-Learning credits
- the provincial literacy requirement

---

\*A maximum of 3 credits in English as a second language (ESL) or English literacy development (ELD) may be counted towards the 4 compulsory credits in English, but the fourth must be a credit earned for a Grade 12 compulsory English course. \*\* In Groups 1, 2, and 3, a maximum of 2 credits in French as a second language can count as compulsory credits, one from Group 1 and one from *either* group 2 *or* group 3. \*\*\*A maximum of 2 credits in cooperative education can count as compulsory credits. +The 12 optional credits may include up to four credits earned through approved dual credit courses.