



WELCOME TO CEDARBRAE'S GRADE 8 INFORMATION NIGHT

CEDARBRAE
COLLEGIATE
INSTITUTE



Hic Patet In Genius Campus - "Here is a place where
talent thrives"

Table of Contents

| | Page |
|---|--------------------|
| School Highlights | 1 - 5 |
| <u>Grade 9 Elective Courses</u> | |
| • Arts (Drama, Music, Visual Arts) | 6 & 7 |
| • Business | 8 & 9 |
| • Technological Studies | 10 |
| • Family Studies | 11 |
| • Guidance – Skills for Success in Secondary School | 12 |
| • Special Education – GLE – Learning Strategies | 13 & 14 |
| <u>Grade 9 Core Subjects and Special Programs</u> | |
| • English and English as a Second Language | 15 & 16 |
| • Geography | 17 |
| • Health and Physical Education | 18 |
| • International Languages | 19 & 20 |
| • Math | 21 |
| • Science | 22 |
| <u>Special Programs</u> | |
| • CCi STEM (Central Student Interest Program) | 23 & 24 |
| • Co-operative Education & Apprenticeship | 25 |
| • Specialist High Skills Major (SHSM) – Business | 26 - 28 |
| • Specialist High Skills Major (SHSM) – Construction | 29 - 31 |

| | |
|---|--------------------|
| Certificates of Achievement | 32 & 33 |
| Diploma Requirements | 34 |
| Cedarbrae C. I. Course Chart for 2025-2026 | 35 - 38 |

For more information about Cedarbrae visit
<https://schoolweb.tdsb.on.ca/cedarbraeci>

Facilities Highlights

Family Studies:

5 complete lab kitchens
Washer and Dryer
Sewing Lab with 24 Machines
Electronic babies: Raising Healthy Children
Shared Chromebook (30), Cart for research projects



Library/Resource Centre:

See page 5

Performing Arts:

Professional theatre/auditorium facility
Studio 502: Performance space classroom and video production studio
Full Drama Room and Performance space – Room 255
Full Steel Band facilities
Fully equipped music room for band and vocal classes
Piano Keyboards for the keyboarding classes
Acoustic Classical guitars for guitar classes



Physical Education:

Outdoor track
3 gyms, upgraded weight room, pool, dance/yoga studio

Technology:

Computer labs (including 2 communications technology labs)
2 auto shops (including small engines & marine repairs)
1 construction/woodworking shop
1 construction/electrical wiring lab
1 manufacturing technology shop
1 CAD (computer assisted drafting) lab
1 design & technology shop
1 integrated technology lab



Visual Arts:

Two Art studios with a full range of equipment and supplies
Digital Art Computer Lab
Ceramics facilities - 2 kilns
Crafts classes offered
Ongoing Student mural projects throughout the school
Art Club
Indigenous focused NAC10 grade 9 classes



Co-Curricular Highlights

Arts Department

Drama / Film:



Over 4 decades of participating in *The Sears Drama Festival/National Theatre School Festival*. 19 times in the Ontario Finals of *Sears Festival/National Theatre School Festival*
Represented Ontario in *National Secondary Theatre Festivals*
School Musicals – *Aladdin* and *High School Musical*
Willy Wonka coming in April 2025
Trips to Musicals - *Mean Girls*
Drama Trips twice a year to Young People's Theatre
Spoken Word guest artist Dwayne Morgan (from Scarborough)

Music:

Opportunities for student performance throughout the school and community
Field trips to the Toronto Symphony Orchestra, Canadian Opera Company, Massey Hall, and more
Cross-curricular initiatives (*Willy Wonka* musical going up in April 2025 with the Drama department)

Visual Art



Art Club open to all students
Engaging Field trips to *AGO*, *One-of-a-kind Craft show*, *Immersive Van Gogh*
Cross-curricular projects with other departments schoolwide
Student work displayed throughout the school & community
Student centered projects
Student murals throughout the school
Community Partnerships- Students work displayed in *Artist Walkway Scarborough Hospital General Division*, *Delisle Youth Services Art show* and *Edge Youth Art Show*

Athletics: Winter 2023: Junior Girls Volleyball: Tier 1: Silver Medal
Indoor Girls Soccer: Tier 1 Silver Medal



Spring 2024: Outdoor Girls Soccer: Tier 1: East Region Champions
Outdoor Junior Boys Soccer: Tier 2: East Region Champions
Archery: East Region Champions and Defending City Champion
Fall 2024: Cross Country 20w4: City Championships Qualifiers (Junior Boys Team and 3 Top 15 girls finishes)
Varsity Boys Rugby 7s 2024: Tier 2: Advanced to repechage

Business:

Field Trips, competitions, contests and clubs including DECA, offer a variety of real-world business experiences. We also offer a Business SHSM Program with Red Seal OSSD. Part of the Grade 9 STEM Program in conjunction with English and Science. Modern classrooms with updated Technology throughout the department.



History/Social Sciences: Our students participate in field trips to the Toronto Zoo, The Royal Ontario Museum, and Casa Loma.
 Clubs: Model U.N. and a Debate Team
 The history department is also pleased to offer cultural and educational opportunities for students to travel around the world.



School trips include:
 2020 - Traveling to Europe to attend the ceremonies for the 75th anniversary of VE Day (Victory in Europe)
 2019 - Florence, Rome and Paris
 2017 – 100th Anniversary of Vimy Ridge (visited Paris)
 2015 – England, France, Switzerland and Germany

Mathematics: The Math Club prepares students for competitions sponsored by the University of Waterloo (Pascal, Cayley, Fermat, Euclid, Fryer, Galois, Hypatia) and McMaster.

Modern Languages:

Student Exchange: ISE Ontario, CEEF
 Conferences: AMUN Conference
 French for the Future
Le Salon du livre
 Contests: The Toronto French Contest
Les Concours d'art oratoire
 Certification: DELF



Science: **Canada's Wonderland Roller Coaster Contest**
 Teams of Cedarbrae Physics students build a model roller coaster and present their model at Canada's Wonderland Physics Day in the spring.

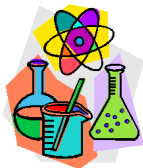

Science Extra Help Seminars
 Offers the opportunity for students to review, plan and prepare assignments and evaluations

STEAM Team: Engineering/Leadership Presentations put on by CCI students @ feeder schools.

Contests: Our students have the opportunity to participate in various national Science competitions including: CHEM 13 NEWS EXAM (University of Waterloo); Sir Isaac Newton Physics Examination (University of Waterloo); Senior Biology Exam (University of Waterloo); and the Michael Smith Science Challenge (UBC).

Eco Club
 Students in the Eco Club participate in a wide variety of initiatives and activities to help Cedarbrae go green!

Technology Department: Specialist High Skills Major – Construction



Transportation: Students have been involved in custom projects (prepared vintage cars for car shows.) Students participated in the on-site preparation of the car display area.

The automotive program (Transportation) has provided many students with a seamless transition to an apprenticeship or a specific automotive program at local colleges.

Offers “Women on Wheels” a course for females wishing to learn to maintain their vehicles.



Photography: Students have participated in various skills competitions. Photography students participate in photographing major school events commencement, prom, athletic events (home and away games), assemblies, photography competitions, and day to day events.

Student Projects are always on display in the Main Office and in show cases around the school.



Woodworking: Students have constructed items for use in the community, such as benches for Scarborough Hospital General Division. Items have been made and sold to staff to raise money for the breakfast club.



Communications Technology: A popular Tech course that affords students credentials for University and College prerequisites. Students work on computer related projects, which include, Power Point presentations, Adobe Flash 2D Animation, Photoshop & Photo Editing, Videography, Web Page Design, Graphic Design, Newsletter Design, Sound Recording and Video Editing. Two of our students came 4th in the Provincial Skills competition in 2D Animation held last year.

Your hub of learning all throughout high school!

THE CEDARBRAE COLLEGIATE LIBRARY!

Visit us before school, at lunch, or after school



Makerspace



Gaming Club



VEX Robotics

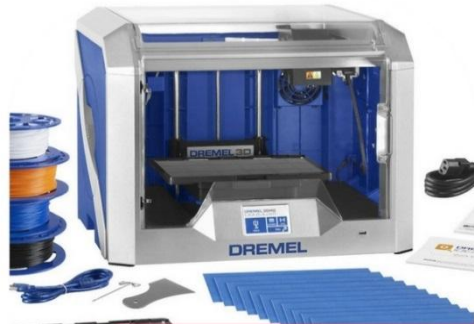

3D Printing

We also have quiet workspaces, group study areas, 2 computer labs, new release fiction books AND MORE! Come check it out!

GRADE 9 ELECTIVE COURSE DESCRIPTIONS



THE ARTS



DRAMATIC ARTS – ADA101 – OPEN

This course emphasizes the active exploration of dramatic forms and techniques, using material from a wide range of authors, genres, and cultures. Students will construct, discuss, perform, and analyze drama, and then reflect on the experiences to develop an understanding of themselves, the art form and the world around them.

INSTRUMENTAL MUSIC (BAND/WOODWINDS/BRASS) – AMI101 – OPEN

Students will focus their work on the various aspects of musical performance through the study of a woodwind, brass or percussion instrument in a band setting. This course is for students who already play an instrument.

MUSIC – KEYBOARD MUSIC – AMK101 – OPEN

Students will focus on the skills specific to the piano keyboard and will learn authentic repertoire.

MUSIC – VOCAL – AMV101 – OPEN

This course is designed for students wishing to learn about singing and participate in a choir setting.

FIRST NATIONS, MÉTIS, AND INUIT STUDIES (Visual Arts)

Expressions of First Nations, Métis, and Inuit Cultures – NAC101 – OPEN

This course will explore a variety of contemporary and traditional First Nations, Métis, and Inuit art forms. This course offers an overview of visual arts as a foundation for further study. Students will become familiar with the elements and principles of design and the expressive qualities of various materials. They will create art works to express their own ideas and understanding of Aboriginal identity, relationships, and sovereignty by using a range of media, processes, techniques, and styles.

ARTS VISUELS - AVI105 - Immersion French/Extended French - OPEN

This course is for French Immersion students.

This course offers an overview of visual arts as a foundation for further study. Students will become familiar with the elements and principles of design and the expressive qualities of various materials through working with a range of materials, processes, techniques, and styles. They will learn and use methods of analysis and criticism and will study the characteristics of particular historical art periods and a selection of Canadian art and the art of other cultures.

NOTE: This course is for all grade 8 students from both the Extended French and Immersion French programs who are starting grade 9 in September 2025.

VISUAL & PERFORMING ARTS



**GRADE 9 REQUIREMENT IS ONE OF:
BAND, DRAMA, KEYBOARD,
VISUAL ART, VOCAL**



BAND

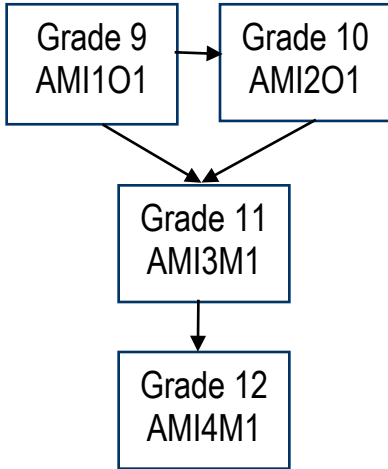

DRAMA

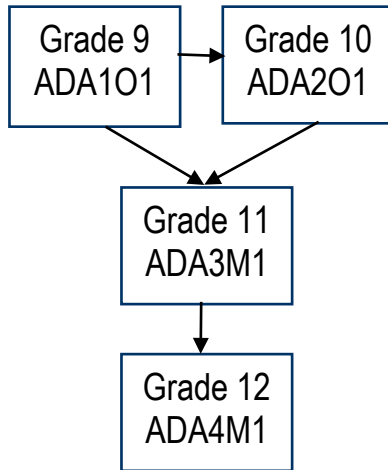

FILM

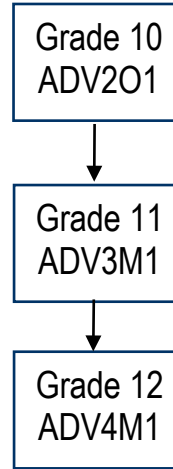

GUITAR

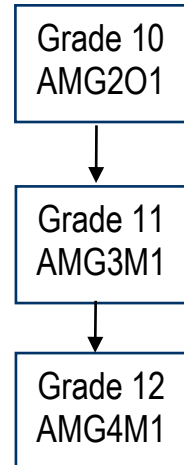

VOCAL

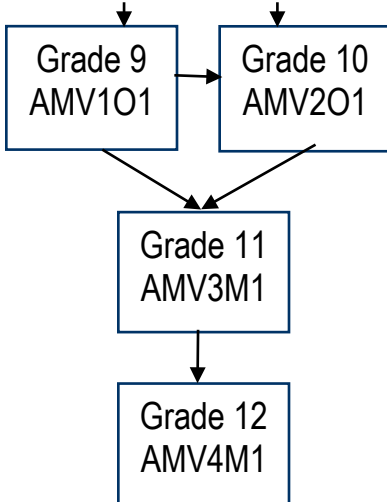

KEYBOARD MUSIC

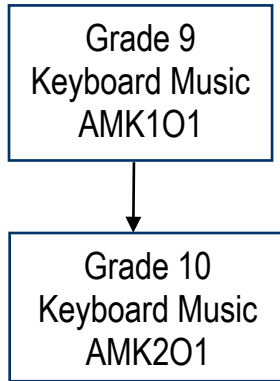

VISUAL ART

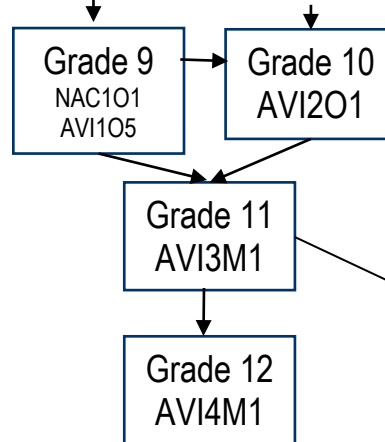

SPECIAL FOCUS ART

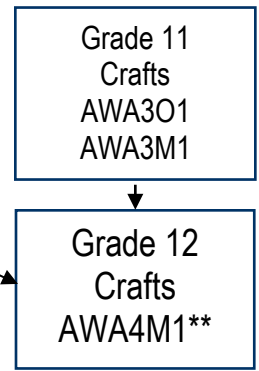

** Requires AVI3M1 OR AWA3M1

LANGUAGE OPTIONS

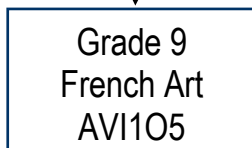



BUSINESS STUDIES



Building the Entrepreneurial Mindset, Grade 9, Open (BEM10)

In this course, students will learn what makes an entrepreneur thrive and the skills required to succeed in today's business environment. Students will begin to develop their own entrepreneurial mindset, and learn why it's important to take initiative, adapt to change, find creative solutions, and understand the financial considerations of entrepreneurship. This hands-on course will use business software and applications to help students plan and develop their entrepreneurial ideas and learn how to present them to a target audience. Throughout the course, students will enhance their communications skills as well as develop and refine their project management skills, including goal setting, time management, and networking.

BUILDING THE ENTREPRENEURIAL MINDSET

Course Codes:

- English -BEM101
- ESL - BEM108
- CCi STEM - BEM10P

Business Studies Flow Chart

BEM10
 Building the Entrepreneurial Mindset
 Grade 9 Open

BEP20
 Launching and Leading a Business
 Grade 10 Open

BAF3M
 Financial Accounting Fundamentals
 Grade 11
 College/University

BAI3E
 Accounting Essentials

Any University, University/College or College Preparation course in Business Studies or Canadian and World Studies.

BDI3C
 Entrepreneurship The Venture
 Grade 11
 College

BMI3C
 Marketing Goods and Services
 Grade 11
 College

BAT4M
 Financial Accounting Principles
 Grade 12
 College/University

IDC4U
 Financial Securities
 Grade 12
 University (IDCFIN)

BOH4M
 Business Leadership: Management Fundamentals
 Grade 12
 College/University

BBB4M
 International Business Fundamentals
 Grade 12
 College/University

IDC4U
 Sports and Entertainment Marketing
 Grade 12
 University (IDCSPO)

**Earn a Business Certificate by completing 5 Credits in Business Studies from the choices above!*

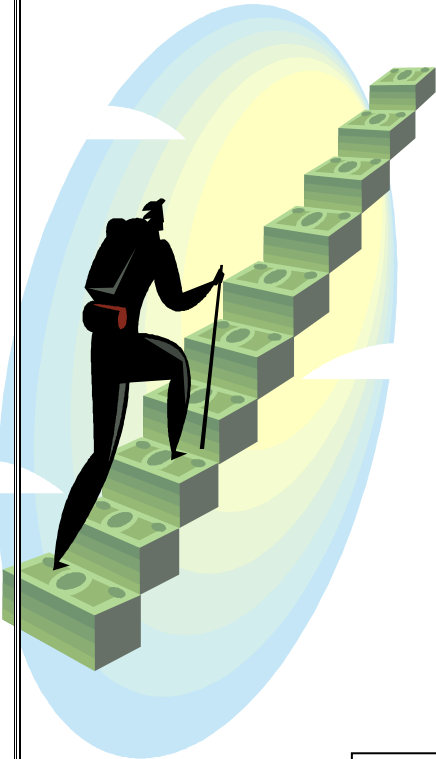



TECHNOLOGICAL STUDIES CURRICULUM INFORMATION GRADE 9



Technology and the Skilled Trades, Grade 9, Open (TAS10)

This hands-on course enables students to further explore the engineering design process and develop other technological knowledge and skills introduced in earlier grades. Students will design and safely create prototypes, products, and/or services, working with tools and technologies from various industries. As students develop their projects to address real-life problems, they will apply technological concepts such as precision measurement, as well as health and safety standards. Students will begin to explore job skills programs and education and training pathways, including skilled trades, that can lead to a variety of careers.

During their stay in TECHNOLOGICAL STUDIES, we offer the students as much variety as possible.

| TOPIC AREA | BRIEF SAMPLE OUTLINE |
|-----------------------|---|
| TRANSPORTATION | <ul style="list-style-type: none"> - Acquire knowledge, skills, and values in a variety of learning experiences in the fields of: Transportation - air, land, and sea - Environmental concerns - Impact on society |
| DRAFTING | <ul style="list-style-type: none"> -Acquire knowledge, skills, and values in a variety of learning experiences in the field of drafting line work -Fundamentals of multi -view drawings (Orthographic and Isometric) -Using traditional as well as computer assisted drawings (CAD) |
| COMMUNICATIONS | <ul style="list-style-type: none"> -Acquire knowledge, skills, and values in a variety of learning experiences in the field of communications -Audio, video, photographic and computer graphics use as it applies to these areas |
| WOODWORKING | <ul style="list-style-type: none"> -Acquire knowledge, skills, and values in a variety of learning experiences in the field of woodworking -Safe use of hand and power tools, wood identification, joinery, and work on activity-based projects |
| NOTE | <p>Classes in grade nine may be exposed to all the above topics however it is technology teacher dependent; every effort is made to expose the student to as many areas as possible. All technology areas have key components that will be exposed; Safety, Measurements, Drawings and Project based learning. Evaluation of students is based on their practical work (projects), as well as their theory work (tests, assignments, presentations). The student's mark reflects their complete grade nine technology course.</p> |



SOCIAL SCIENCE AND THE HUMANITIES



EXPLORING FAMILY STUDIES - HIF1O1 – OPEN - For English as a Second Language students we offer HIF2O8

This course explores, within the context of families, some of the fundamental challenges people face: how to meet basic needs, how to relate to others, how to manage resources, and how to become responsible members of society. Students will explore adolescent development and will have opportunities to develop interpersonal, decision-making, and practical skills related to daily life. They will learn about the diverse ways in which families function in Canada and will use research skills as they explore topics related to individual and family needs and resources.



Exploring Family Studies

HIF1O1/HIF2O8

Grade 9

Open

WHO ARE YOU? Do you have the knowledge and skills that are needed to make the transition to adulthood? Learn some practical skills related to daily family living.

Topics to be covered will include:

- ◆ Who Am I ?
- ◆ Function of the Family
- ◆ Diversity of Families
- ◆ Managing our resources—time and money



Guidance – Skills for Success in Secondary School

Skills for Success in Secondary School – GLS101 – OPEN - For English as a Second Language student we offer GLS208

This Course is for students who do not have an IEP (Individual Education Plan)

This course focuses on learning strategies to help students become better, more independent learners. Students will learn how to develop and apply literacy and numeracy skills, personal management skills, and interpersonal and teamwork skills to improve their learning and achievement in school, the workplace and the community. The course helps students build confidence and motivation to pursue opportunities for success in secondary school and beyond.

Guidance and Career Education



As students look forward to beginning high school, it's hard to believe that in just a few years they will be taking another big step into the world of work. After graduation, students may be heading to apprenticeship, college, university, or directly to work, and Cedarbrae has a comprehensive program to help each student make career and educational plans. Additionally, the Cedarbrae Student Services Webpage provides online resources to assist students with career and educational planning. (<https://schoolweb.tdsb.on.ca/cedarbraeci/Guidance>)

Counsellors and teachers monitor student success and assist students as they make pathway choices. Students may also make appointments with counsellors for career and educational counseling.

Whether or not a student has a specific career in mind, it is important to select both compulsory and optional courses carefully so that requirements for post-secondary education or training are met. Cedarbrae offers a wide variety of optional courses which can help students discover interests and strengths and develop skills leading to career choices. All students in Grade 10 are required to successfully complete the ½ credit Career Studies course.



SPECIAL EDUCATION – Learning Strategies

LEARNING STRATEGIES – GLE109 – OPEN

This course explores learning strategies and helps students become better, more independent learners while increasing their personal management skills, both in school and in other contexts. Students will learn how to develop and apply a range of strategies to improve their learning and achievement, particularly their literacy, numeracy, communication, and planning skills. This course will increase students' confidence, motivation, and ability to learn.

Prerequisite: Students must have an Individual Education Plan and recommendation of Principal



Special Education

Students who have an Individual Education Plan are considered part of Cedarbrae's Special Education Department. The Special Education department offers supports, accommodations and strategies to help facilitate student success.

Learning Strategies Course - GLE1/2/3/40 (students who have an IEP only)

GLE classes are split into grade 9/10 and grade 11/12. These courses are designed to be smaller in size and give students a chance to complete work from their other classes. The teacher is able to help students with academic support when necessary and works with students on learning skills for success in GLE. There is no exam in the course, but there are a series of assignments and a course culminating at the end. This course is a nice balance for students to complete course work, while getting academic support for other classes at the same time.

Course curriculum includes strategies that help develop skills students need to be successful. Determining your learning style, organizational skills, goal setting, test-taking and memorization strategies, time management skills, self-advocacy, and improving basic literacy and numeracy skills are some of the key points covered in these courses.

Special Education

RESOURCE ROOM – 319 (every student in the school has access to this room)

The resource room is a place for students to receive one on one support for any of their courses. They can also receive computer and printer access, a quiet space for working or a place to write a test/quiz. Students advocate for themselves and ask their teachers to come up to the room. Students can come for 15-20 minutes or the entire period, depending on what type of academic support they are looking for.

The resource room has 10 computers available for student use and a printer. The room also has a chrome book cart that allows IEP students to have technology with them for a particular class if needed. They need to speak with the special education teachers to discuss how to access the computers.

All students in the school also have access to the Read and Write program. This is a computer program that allows speech to text assistance, text to speech assistance, a dictionary, reading text feature and so much more. Ask your child to show you this amazing program. This program helps lessen barriers for written expression, reading comprehension, word decoding or recognition that many of our student's experience allowing them more opportunity to demonstrate their learning.





ENGLISH

ENGLISH – ENL1W1 - De-streamed

This course enables students to continue to develop and consolidate the foundational knowledge and skills that they need for reading, writing, and oral and visual communication. Throughout the course, students will continue to enhance their media literacy and critical literacy skills, and to develop and apply transferable skills, including digital literacy. Students will also make connections to their lived experiences and to society and increase their understanding of the importance of language and literacy across the curriculum.

The English department is constantly updating the selection of novels used in the courses to include a wide variety of genres and perspectives. Each course explores poignant themes such as Bildungsroman, dystopia, and Indigenous perspectives. The Creative Writing course has returned to offer students the opportunity to explore storytelling with short stories, poetry, and screenplay writing. More interactive activities and guest speakers are also returning to the courses with new ways of using technology correctly to enhance learning.

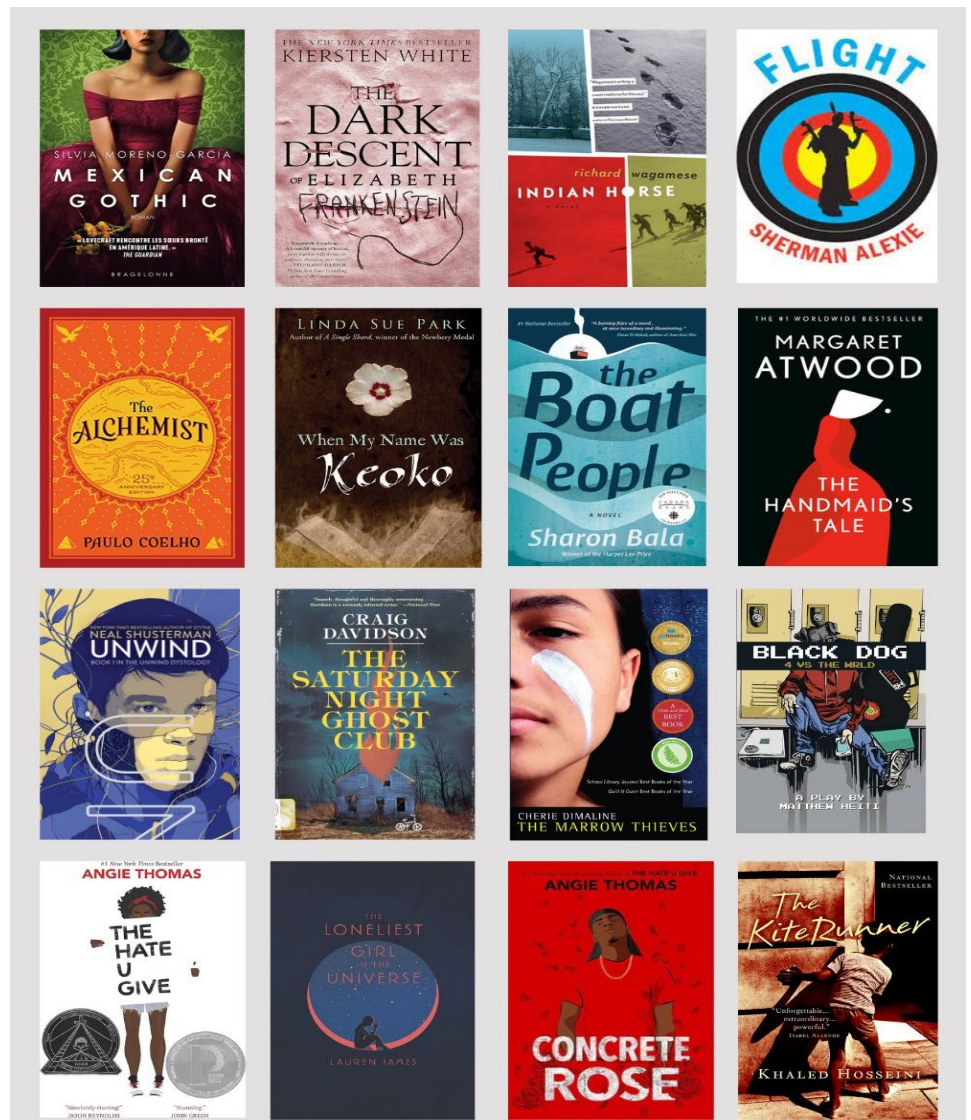



ENGLISH AS A SECOND LANGUAGE

At Cedarbrae, we offer 5 levels of ESL in preparation for the regular stream of English classes. Students will be placed at the level suggested by the TDSB Assessment Centre upon entry to the school.

We also have LEAP (Literacy Enrichment Academic Program). LEAP is an accelerated program for students who have recently arrived in Ontario who have limited prior schooling

Students have the opportunity to take ESL Geography (CGC1D8), ESL Information & Communication Technology and Business (BTT1O8), ESL Skills for Success in Secondary School (GLS1O8), and ESL Exploring Family Studies (HIF2O8). These courses will help strengthen the student's oral skills, confidence, and creativity.

Students and parents also have access to settlement workers in the school who help families transition and acclimatization to a new environment.

GEOGRAPHY DEPARTMENT



Grade 9

GEOGRAPHY OF CANADA (CGC1W)

(De-streamed, French Immersion & ESL Options Available)

Issues in Canadian Geography, Grade 9, De-streamed (CGC1W)

Students will explore relationships within and between Canada's natural and human systems and how they interconnect with other parts of the world. Students will also examine environmental and economic issues, and their impact related to topics such as natural resources and industries, careers, land use and responsible development, and sustainability. In addition, students will understand the connections that diverse communities and individuals have with the physical environment and each other throughout Canada, including First Nations, Métis, and Inuit perspectives. Students will apply geographic thinking, use the geographic inquiry process, and use geospatial technologies throughout their investigations.

Health & Physical Education



PHYS. ED A COURSE FOR THE PEOPLE-- BY THE PEOPLE

CHOOSE YOUR ACTIVITIES

| TERRITORY GAMES | NET / WALL GAMES | TARGET GAMES | STRIKING / FIELDING GAMES | OTHER |
|------------------------|-------------------------|---------------------|----------------------------------|----------------------------|
| Basketball | Badminton | Archery | Baseball | Pool |
| Football | Volleyball | Bocce | Softball | Dodgeball |
| European handball | Pickleball | Curling | Cricket | Fitness |
| Hockey | Table tennis | Disc golf | Kick-ball | Track & Field |
| Lacrosse | Spikeball | Disc slam | | Yoga |
| Soccer | Tennis | Horse shoes | | Meditation/ Mindfulness |
| Rugby | | | | |
| Ultimate | | | | |



Healthy Active Living Education, Grade 9, Open (PPL10 offered in English and French)

This course equips students with the knowledge and skills they need to make healthy choices now and lead healthy, active lives in the future. Through participation in a wide range of physical activities, students develop knowledge and skills related to movement competence and personal fitness that provide a foundation for active living. Students also acquire an understanding of the factors and skills that contribute to healthy development and learn how their own well-being is affected by, and affects, the world around them. Students build their sense of self, learn to interact positively with others, and develop their ability to think critically and creatively.

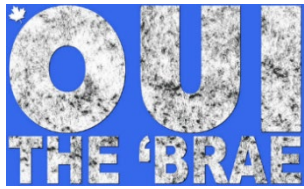

International Languages (French & Spanish)

Unlock your language power and develop lifelong language learning skills with our French and Spanish courses. Our goal is to inspire our learners to fall in love with language learning through the use of games and modern teaching techniques that move away from traditional grammar and conjugation. We are proud to have built the largest Spanish department in the TDSB and look forward to welcoming you and your children to Braeville next year. Oui the Brae! Si da Brae!

GRADE 9 FRENCH AS A SECOND LANGUAGE COURSES

CORE FRENCH - FSF1D1 - ACADEMIC

This course provides opportunities for students to communicate and interact in French with increasing independence, with a focus on familiar topics related to their daily lives. Students will continue to develop language knowledge and skills by using language-learning strategies introduced in the elementary Core French program and will apply creative and critical thinking skills in various ways. They will also enhance their understanding and appreciation of diverse French-speaking communities and will develop the skills necessary to become life-long language learners. **Prerequisite:** Minimum of 600 hours of elementary Core French instruction, or equivalent

CORE FRENCH – INTRODUCTORY/BEGINNER - FSF1O1 – OPEN This is an introductory course for students who have little or no knowledge of French or who have not accumulated the minimum of 600 hours of elementary Core French instruction. Students will begin to understand and speak French in guided and structured interactive settings and will develop fundamental communication skills through discussing situations and issues that are relevant to their daily lives. Throughout the course, students will develop their awareness of diverse French-speaking communities in Canada and acquire an understanding and appreciation of these communities. They will also develop a variety of skills necessary to become life-long language learners. **Prerequisite:** None

FRENCH IMMERSION - FIF1D5 - ACADEMIC

This course provides opportunities for students to speak and interact in French independently in a variety of real-life and personally relevant contexts. Students will develop their ability to communicate in French with confidence by using language-learning strategies introduced in the elementary French Immersion program. Students will enhance their knowledge of the language through the study of French-Canadian literature. They will also continue to increase their understanding and appreciation of diverse French-speaking communities and to develop the skills necessary to become life-long language learners.

NOTE: This course is for all grade 8 students from both the Extended French and Immersion French programs who are starting grade 9 in September 2025.

GRADE 9 COURSES OFFERED IN FRENCH IMMERSION

NOTE: These courses are for all grade 8 students from both the Extended French and Immersion French programs who are starting grade 9 in September 2025.

| <i>COURSE TITLE</i> | <i>COURSES</i> |
|---|--|
| FRANÇAIS | FRENCH - FIF1D5 <i>(For both Immersion and Extended Students)</i> |
| ENJEUX GEOGRAPHIQUES DU CANADA | FRENCH - CGC1D5 <i>(For both Immersion and Extended Students)</i> |
| ÉDUCATION PHYSIQUE ET HYGIÈNE (FILLES) | FRENCH - PPL1OG <i>(For both Immersion and Extended girls)</i> |
| ÉDUCATION PHYSIQUE ET HYGIÈNE (GARÇONS) | FRENCH - PPL1OQ <i>(For both Immersion and Extended boys)</i> |
| ÉDUCATION PHYSIQUE ET HYGIÈNE (FILLES & GARÇONS) | FRENCH - PPL1OK <i>(For both Immersion and Extended Students)</i> |
| MATHÉMATIQUES | FRENCH - MTH1W5 <i>(For Immersion Students)</i> ENGLISH - MTH1W1 <i>(For Extended Students)</i> |
| SCIENCE | FRENCH - SNC1W5 ENGLISH - SNC1W1 <i>(For both Immersion and Extended Students)</i> |
| VISUAL ART (IMMERSION or EXTENDED) | FRENCH - AVI1O5 <i>(For both Immersion and Extended Students)</i> |



If you love the natural world and want to understand your place within it, Cedarbrae Science has a lot to offer. Push back boundaries of the unknown and develop your passion for science with us. Our programming will expand your knowledge and interests and help you learn about your place in nature.

With our enthusiastic teachers, Cedarbrae Science is a great place to learn. We have eight fully equipped labs where students investigate principles of biology, chemistry, physics and earth and space science. Experiment in areas of density, microscopy, electric circuits, dissections, bacterial culture, chemical reactions, optics, kinematics and more.

Make the most of your time with us by being involved in academic life. The Cedarbrae Science department offers multiple opportunities to engage in academic contests, field trips, clubs, and mentorship programs.

We offer grade nine and ten courses in French for students in the Immersion program. Furthermore, our ever-expanding STEM pathway encourages innovation in science at all levels. By applying for this program, you gain the opportunity to explore STEM the way you want through our math, science, technology, or kinesiology pathways.

In recognition of our students' commitment to our department, we offer two Science Certificates upon graduation. Regular requirements are for those students who have completed five senior science courses. Honours requirements are for students who have completed six or more senior science courses. The future of science and technology has never been so exciting or so promising. We invite you to be part of this exciting journey of discovery.

SCIENCE - SNC1W1 – DE-STREAMED

This course enables students to develop their understanding of concepts related to biology, chemistry, physics, and Earth and space science, and to relate science to technology, society, and the environment. Throughout the course, students will develop and refine their STEM skills as they use scientific research, scientific experimentation, and engineering design processes to investigate concepts and apply their knowledge in situations that are relevant to their lives and communities. Students will continue to develop transferable skills as they become scientifically literate global citizens.

SCIENCE - SNC1W5 – DE-STREAMED - This course is for French Immersion/Extended French Students.

This course enables students to develop their understanding of concepts related to biology, chemistry, physics, and Earth and space science, and to relate science to technology, society, and the environment. Throughout the course, students will develop and refine their STEM skills as they use scientific research, scientific experimentation, and engineering design processes to investigate concepts and apply their knowledge in situations that are relevant to their lives and communities. Students will continue to develop transferable skills as they become scientifically literate global citizens.



CEDARBRAE COLLEGIATE *INNOVATION* STEM (CCi STEM)

At Cedarbrae we are passionate about STEM education, and we want YOU to be a part of Cedarbrae Collegiate *innovation*! By applying for our program, you gain an opportunity to explore STEM the way you want through our math, science, technology, or kinesiology pathways. In grade nine you will have the unique opportunity of completing your science, English, and business credits in a combined three course package working collaboratively on projects that involve all three subjects.

Throughout your 4 years of the CCi program you will explore learning opportunities that include:

- Field trips
- Problem based learning
- Industry expert guest speakers
- Post secondary outreach
- Cross curricular classes
- Technology embedded learning
- Game based learning

Upon completion of the program, students will be able to investigate the world, weigh perspectives, communicate ideas, take action and apply disciplinary and interdisciplinary expertise in school and beyond.

Required Courses

| Grade 9 | Grade 10 | Grade 11 | Grade 12 |
|----------------|-----------------|---|---|
| ENL1WP | ENG2DP | <i>Select at least one Grade 11 course in:</i> | HSE4MP |
| SNC1WP | SNC2DP | Computer Science | <i>Select at least one Grade 12 course in:</i> |
| BEM1OP | ICD2O1 | Science | Computer Science |
| | | Technology | Kinesiology |
| | | | Science |
| | | | Technology |

INNOVATORS WANTED

CCi Student Pathway

Your roadmap to innovation

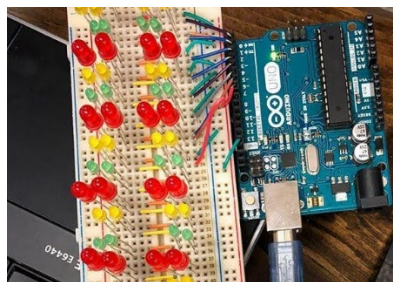
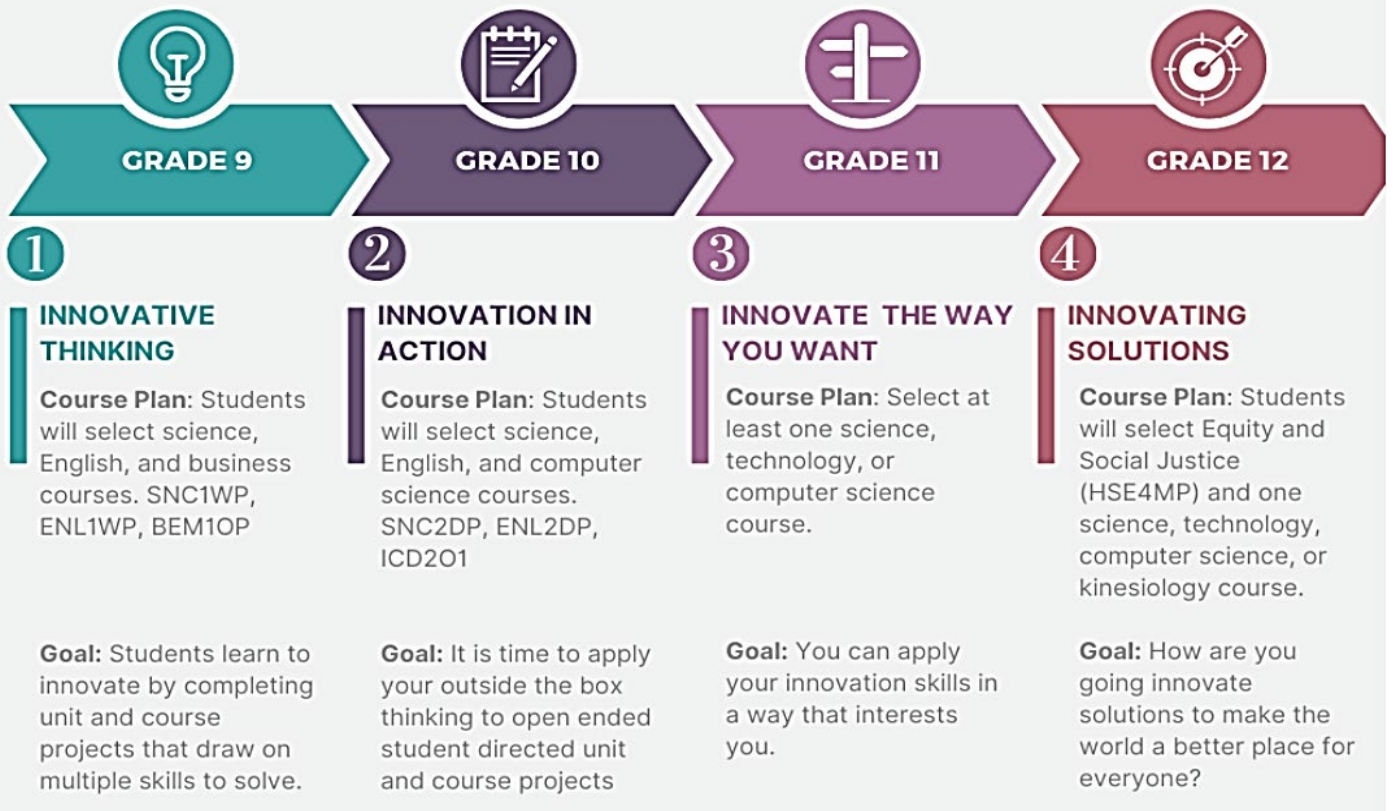



Co-operative Education and Apprenticeships:

In their senior years, students can earn up to 4 credits per semester and gain valuable work experience through the co-operative education program. Students may also choose to continue at Cedarbrae in a co-op program for an additional semester after completing graduation requirements.

Students find gaining real work experience in a chosen career through the co-op program helps them to be sure of their post-secondary program decisions, choose specific courses, get advice, and make contacts with people in their chosen field.

Some college and university programs require students to have experience in the career field and references from a supervisor. The experience and references are often gained through co-op. Also, post-secondary education is more meaningful when the student has already been involved in seeing how theory is applied in the workplace.

If a student is interested in an apprenticeship, they can begin the apprenticeship training through the Ontario Youth Apprenticeship Program (OYAP) in the co-op program while they are completing their last credits for high school. After graduation from Cedarbrae, students who continue in an apprenticeship are eligible to have 80% of their college tuition apprenticeship training paid by the province under OYAP.



Training through apprenticeship is available in a wide variety of career areas including Early Childhood Educator, Chef, Automotive Service Technician, Special Events Planner, Plumber, Tool & Die Maker, Child & Youth Worker, Welder, and Hairstylist. More information about apprenticeship training can be found at: <https://www.ontario.ca/page/apprenticeship-ontario>

Students who enter the work force directly after graduating benefit from the co-op program in several ways. First, they have demonstrated the essential skills that all employers are looking for. They have developed specific skills in their field of work, and because the student has experience and references, they are more successful in finding a full-time job in the field they are interested in.

All co-op students learn about working safely, employment standards and laws in Ontario, job search techniques, resume and interview preparation, communicating effectively, selecting careers based on interests, skills, and temperaments, learning styles, job trends, managing money, conflict resolution, stress management and other topics that prepare them to be successful in the adult work world.



The Specialist High Skills Major (SHSM) is a specialized program approved by the Ministry of Education that allows students to focus their learning on a specific economic sector while meeting the requirements of the Ontario Secondary School Diploma (OSSD).

| Requirements | Benefits |
|--|---|
| <ul style="list-style-type: none"> • A bundle of 9 grade 11 and 12 credits. <ul style="list-style-type: none"> • 4 major credit courses connected to Business (see reverse) <ul style="list-style-type: none"> • other required credits in English (gr. 11 and/or 12), and math (gr. 11 and/or 12) depending on the pathway (A, C, U, W) • 2 cooperative education credits that are tied to the Business sector • 6 sector recognized certification and/or training programs <ul style="list-style-type: none"> • 4 compulsory (CPR and Standard First Aid, WHMIS, Health and Safety, and Customer Service) • A choice of 2 electives from a list of additional certifications • Experiential learning and career exploration activities within the sector • Reach ahead experiences connected with the student’s post-secondary pathway • A Sector Partnered Contextualized Component (SPCC) including one of the following options: Innovation, Creativity, and Entrepreneurship (ICE) training; sector-delivered contextualized coding; or sector-delivered mathematical literacy. The SPCC will require approximately six hours to complete. | <p><i>The SHSM program will enable students to:</i></p> <ul style="list-style-type: none"> ➤ choose a variety of Business-related Grade 11 and 12 courses ➤ customize their secondary school education to suit their interests and talents ➤ develop specialized knowledge and skills ➤ complete activities related to Business in business, math, English, science, technology, law, and/or computer science courses ➤ earn credits that postsecondary educational institutions and the Construction sector recognize ➤ gain sector-recognized certification and career-relevant training ➤ participate in Experiential Learning activities to learn about real-life job situations ➤ develop Essential Skills and work habits documented through the Ontario Skills Passport ➤ identify, explore, and refine career goals and make informed decisions about their future involving Reach Ahead activities ➤ remain flexible, with the option to shift between pathways, should their goals and plans change ➤ earn an Ontario Secondary School Diploma with an embossed red seal and formal recognition on their Ontario Student Transcript ➤ receive a SHSM Record documenting their achievement |

Courses offered at Cedarbrae to fulfill the Requirement of 9 Bundled Credits

| | Apprenticeship Pathway | | College Pathway | | University Pathway | | Workplace Pathway | |
|--|----------------------------------|-------------------------|-------------------------|----------------|-----------------------|-------------------------|----------------------|-------------|
| Credits | Grade 11 | Grade 12 | Grade 11 | Grade 12 | Grade 11 | Grade 12 | Grade 11 | Grade 12 |
| Major Credits: Total of 4 major credits taken throughout grade 11 and grade 12 | BAI3E BAF3M BDI3C BMI3C | BAT4M BBB4M BOH4M | BAF3M BDI3C BMI3C | BAT4M BBB4M | BAF3M | BAT4M BBB4M BOH4M | BAI3E | |
| English Credit *1 required in most pathways *2 required in Workplace Pathway | NBE3E NBE3C | ENG4E ENG4C | NBE3C | ENG4C | NBE3U | ENG4U | NBE3E | ENG4E |
| Math Credits *2 required in most Pathways *1 required in Workplace Pathway | MBF3C MEL3E | MAP4C | MBF3C MCF3M | MAP4C | MCR3U MCF3M | MHF4U MCV4U MDM4U | MEL3E | |
| Cooperative Education In current pathway | 2 Credits | | 2 Credits | | 2 Credits | | 2 Credits | |

Exception: If a student obtains a four (4) credit co-op, they may choose to use one additional Co-operative education credit to substitute for one “major” credit and/or one “other required credit” (not from English or Math Categories)

There are NO extra credits required to complete this program.

All required credits may be obtained within the 30 required credits for the Ontario Secondary School Diploma (OSSD).

SAMPLE OCCUPATIONS IN THE BUSINESS SECTOR

| APPRENTICESHIP PATHWAY | COLLEGE PATHWAY |
|---|---|
| <ul style="list-style-type: none"> • Hardware, Lumber, and Building Materials Retailer • Parts Technician • Special Events Coordinator | <ul style="list-style-type: none"> • Accounting Clerk • Administrative Clerk • Banking, Insurance and Other Financial Clerk • Bookkeeper • Professional in Business Services • Insurance Adjuster • Legal Secretary • Loan Officer • Recruitment Officer • Purchasing Agent • Retail and Wholesale Buyer • Specialist in Human Resources • Supervisor-Recording, Distributing and Scheduling |
| UNIVERSITY PATHWAY | WORKPLACE PATHWAY |
| <ul style="list-style-type: none"> • Business Development Officer and Marketing Researcher and Consultant • Economist and Economic Policy Researcher • Executive Assistant • Financial and Investment Analyst • Financial Auditor and Accountant • Mathematician, Statistician, and Actuary • Securities Agent and Broker • Specialist in Human Resources • Social Policy Researcher, Consultant and Program Officer | <ul style="list-style-type: none"> • Accounting Clerk • Administrative Clerk • Banking, Insurance, and Other Financial Clerk • Customer Service Representative • Customs, Ship and Other Broker • Payroll Clerk • Real Estate Agent and Salesperson • Receptionist • Records Management Clerk • Retail Salesperson • Shippers and Receivers • Storekeeper and Parts Clerk |

Specialist High Skills Major: Construction

The Specialist High Skills Major (SHSM) is a specialized program approved by the Ministry of Education that allows students to focus their learning on a specific economic sector while meeting the requirements of the Ontario Secondary School Diploma (OSSD)

Requirements

1. **A bundle of 10 grade 11 and 12 credits.**
 - 4 major credit courses connected to construction and engineering (see reverse)
 - 4 other required credits in English (gr.12), math (gr. 11 and 12), and business OR science (gr. 11 or 12)
 - 2 cooperative education credits that are tied to the Construction and Engineering sector
2. **7 sector recognized certification and/or training programs**
 - 5 compulsory (CPR and Standard First Aid, WHMIS, Health and Safety, Fall Protection)
 - A choice of 2 electives from a list of additional certifications
3. **Experiential learning and career exploration activities within the sector**
4. **Reach ahead experiences connected with the student's post-secondary pathway**
5. **A Sector Partnered Contextualized Component (SPCC) including one of the following options: Innovation, Creativity, and Entrepreneurship (ICE) training; sector-delivered contextualized coding; or sector-delivered mathematical literacy. The SPCC will require approximately six hours to complete.**

Benefits

The SHSM program will enable students to:

- choose a variety of **Construction related Grade 11 and 12 courses**
- customize their secondary school education to suit their **interests and talents**
- develop **specialized knowledge and skills**
- complete **activities related to Construction** in math, English, science, and business courses
- **earn credits** that postsecondary educational institutions and the Construction sector recognize
- gain sector-recognized **certification and career-relevant training**
- participate in **Experiential Learning activities** to learn about real-life job situations
- develop **Essential Skills and work habits** documented through the Ontario Skills Passport
- **identify, explore, and refine career** goals and make informed decisions about their future involving Reach Ahead activities
- remain **flexible**, with the option to shift between pathways, should their goals and plans change
- earn an Ontario Secondary School Diploma with an embossed red seal and formal recognition on their Ontario Student Transcript
- receive a SHSM Record documenting their achievement

Courses offered at Cedarbrae to fulfill the Requirement of 10 Bundled Credits

| | Apprenticeship Pathway | | College Pathway | | University Pathway | | Workplace Pathway | |
|--|--|--|--|--|---|---|-------------------------|-------------------------|
| Credits | Grade 11 | Grade 12 | Grade 11 | Grade 12 | Grade 11 | Grade 12 | Grade 11 | Grade 12 |
| Major Credits: Total of 4 major credits taken throughout grade 11 and grade 12 | TWJ3E TCJ3C TCJ3E TCY3C TCE3E TTJ3C | TWJ4E TCJ4C TCJ4E TCY4C TCE4E TTJ4C | TCJ3C TCY3C TDA3M TDJ3M TTJ3C AVI3M | TCJ4C TCY4C TDA4M TDJ4M TTJ4C AVI4M | TDA3M TDJ3M AVI3M SPH3U | TDA4M TDJ4M AVI4M SPH4U | TWJ3E TCJ3E TCE3E | TWJ4E TCJ4E TCE4E |
| English Credit *1 required in most pathways *2 required in Workplace Pathway | NBE3E NBE3C | ENG4E ENG4C | NBE3C | ENG4C | NBE3U | ENG4U OLC4O | NBE3E | ENG4E OLC4O |
| Math Credits *2 required in most Pathways *1 required in Workplace Pathway | MBF3C MEL3E MCF3M | MAP4C MEL4E | MBF3C MCF3M | MAP4C | MCR3U MCF3M | MHF4U MCV4U MDM4U | MEL3E | MEL4E |
| Business Studies, Science *only 1 of these courses is needed over gr. 11 or 12 | SBI3C BAI3E BDI3C BMI3C | SCH4C | BAF3M BDI3C BMI3C ICS3U SBI3C | BAT4M BBB4M BOH4M SCH4C | BAF3M ICS3U SBI3U SCH3U SPH3U | BAT4M BBB4M BOH4M ICS4U SES4U | BAI3E | GLE4O |
| Cooperative Education In current pathway | 2 Credits | | 2 Credits | | 2 Credits | | 2 Credits | |

Exception: If a student obtains a four (4) credit co-op, they may choose to use one additional Co-operative education credit to substitute for one “major” credit and/or one “other required credit” (not from English or Math Categories)

There are NO extra credits required to complete this program. All required credits may be obtained within the 30 required credits for the Ontario Secondary School Diploma (OSSD).

SAMPLE OCCUPATIONS IN THE CONSTRUCTION SECTOR

| APPRENTICESHIP PATHWAY | COLLEGE PATHWAY |
|---|---|
| <ul style="list-style-type: none"> • Brick and Stone Mason • Carpenter • Construction Millwright • Electrician • Heating and Air Conditioning Contractor • Painter and Decorator • Plumber • Roofer | <ul style="list-style-type: none"> • Architectural Design Technician/Technologist • Civil Engineering Technologist • Construction Estimator, Manager or Technologist • Contractor and Supervisor – Electrical Trades and Telecommunications • Home Inspector • Interior Designer • Residential Home Builder or Renovator |
| UNIVERSITY PATHWAY | WORKPLACE PATHWAY |
| <ul style="list-style-type: none"> • Architect • Civil Engineer • Electrical Engineer • Mechanical Engineer • Structural Engineer | <ul style="list-style-type: none"> • Carpenter Helper • Concrete Finisher • Construction Trades Helper and Labourer • Demolition Worker • Drywall Installer • Helper-Construction Trades • Home Renovator |

CERTIFICATES OF ACHIEVEMENT OFFERED AT CEDARBRAE COLLEGIATE



VISUAL ARTS CERTIFICATE

Cedarbrae is proud to offer courses that cover a variety of traditional and digital media techniques. The **Visual Arts Certificate** is awarded to students who have completed **four (4)** or more courses in AVI, NAC, and AWA.



BUSINESS STUDIES CERTIFICATE

Students who have earned a minimum of **five (5)** credits in Business Studies including credits assigned from grade 9 will earn the **Business Studies Certificate**. Course codes that begin with the letter 'B' will be counted for this certificate along with one IDC4 course in Sports and Entertainment Marketing or Financial Securities.



CORE FRENCH, EXTENDED FRENCH, IMMERSION FRENCH AND SPANISH

Certificate of Bilingual Studies in Extended French will be awarded to students who earn the Ontario Secondary School Diploma and complete **seven (7)** credits in Extended French including 4 "FEF" credits grade 9 to 12.



Certificate of Bilingual Studies in French Immersion will be awarded to students who earn the Ontario Secondary School Diploma and complete **ten (10)** credits in Immersion French including 4 "FIF" credits grade 9 to 12.

Honours Certificate of Bilingual Studies in Extended French will be awarded to students who earn the Ontario Secondary School Diploma and complete **eight (8)** or more credits in Extended French including 4 "FEF" credits grade 9 to 12.

Honours Certificate of Bilingual Studies in French Immersion will be awarded to students who earn the Ontario Secondary School Diploma and complete **eleven (11)** or more credits in Immersion French including 4 "FIF" credits grade 9 to 12.

Certificate of Achievement in Core French will be awarded to students who earn the Ontario Secondary School Diploma and complete **four (4)** Core French credits in "FSF" grades 9 to 12.

Certificate of Achievement in Spanish (International Languages Program) will be awarded to students who earn the Ontario Secondary School Diploma and complete credits in LWSBD1, LWSCU1, and LWSDU1.

PERFORMING ARTS CERTIFICATE (Music, Drama, and Film)



Students who have successfully completed a minimum of **four (4)** credits in music, and/or drama (including film) will be awarded a **Performing Arts Certificate**.

Involvement in extracurricular performance will count as one (1) credit. This will recognize their commitment and background in the area of performing arts. The certificate could be of benefit to students when applying for employment or enrolment in post-secondary arts education. (AMI, AMG, AMK, AMV, ADA, ADV)

PHYSICAL AND HEALTH EDUCATION CERTIFICATE



The **Physical and Health Education Certificate** is awarded to students who have completed a combination of **four (4)** courses in PPL and PAF plus **one (1)** course in PSK4U (Introduction to Kinesiology).

SENIOR SCIENCE CERTIFICATE

Students who have successfully completed **five (5)** senior courses (grade 11 & 12) in science will earn a **Senior Science Certificate**. Students that have successfully completed **six (6)** or more senior science courses (grade 11 & 12) will earn an **Honours Senior Science Certificate**.



CANADIAN WORLD STUDIES & SOCIAL SCIENCE CERTIFICATE

Students who have earned a minimum of **seven (7)** credits in Family Studies, Geography, and/or History including credits assigned from Grade Nine may earn a **Canadian World Studies & Social Science Certificate**. Students that earn **nine (9)** credits in Family Studies, Geography, and /or History will be eligible to receive an **Honours Canadian World Studies & Social Science Certificate**.



TECHNOLOGICAL STUDIES CERTIFICATE

Students who have earned a minimum of **five (5)** credits in technological studies will be awarded the **Technological Studies Certificate**. Course codes that begin with the letter 'T' will be counted for this certificate. This certificate should be of benefit to students seeking employment or applying for admission to post-secondary programs in technical areas.





What do you need to graduate?

If you started Grade 9 in 2024 or in later years, you need the following to get your OSSD (Ontario Secondary School Diploma).

Compulsory credits

You need the following 17 compulsory credits to get your OSSD:

- 4 credits in English (1 credit per grade)
- 3 credits in mathematics (Grade 9, Grade 10 and 1 credit in Grade 11 or 12)
- 2 credits in science
- 1 credit in technological education (Grade 9 or Grade 10)
- 1 credit in Canadian history (Grade 10)
- 1 credit in Canadian geography (Grade 9)
- 1 credit in the arts
- 1 credit in health and physical education
- 1 credit in French as a second language
- 0.5 credit in career studies
- 0.5 credit in civics and citizenship
- 1 credit from the STEM-related course group**

**STEM-related course group: you must complete 1 from the following group:

- business studies
- computer studies
- cooperative education
- mathematics (in addition to the 3 compulsory credits currently required)
- science (in addition to the 2 compulsory credits currently required)
- technological education (in addition to the 1 compulsory credit required)

In addition to the 17 compulsory credits, students must complete:

- 13 optional credits
- 40 hours of community involvement activities
- the provincial literacy requirement
- at least 2 online eLearning credits (students may withdraw/opt out of this requirement)

CEDARBRAE COLLEGIATE INSTITUTE COURSE CHART 2025-2026

| Subject / Course Title | Grade 9 | Grade 10 | Grade 11 | Grade 12 |
|---|----------------------------|--|------------------|-----------------|
| THE ARTS (Drama, Film, Music, Visual Art) | | | | |
| Dramatic Arts | ADA1O1 | ADA2O1 | ADA3M1 | ADA4M1 |
| Film/Video | | ADV2O1 | ADV3M1 | ADV4M1 |
| Music - Instrumental (winds) | AMI1O1 | AMI2O1 | AMI3M1 | AMI4M1 |
| - Vocal | AMV1O1 | AMV2O1 | AMV3M1 | AMV4M1 |
| - Guitar | | AMG2O1 | AMG3M1 | AMG4M1 |
| - Keyboard Music | AMK1O1 | AMK2O1 | | |
| Visual Art - English | NAC1O1 | AVI2O1 | AVI3M1 | AVI4M1 |
| - French Immersion/Extended French | AVI1O5 | | | |
| Visual Arts – Crafts - College / University - Open | | | AWA3M1 AWA3O1 | AWA4M1 |
| BUSINESS STUDIES | | | | |
| Building the Entrepreneurial Mindset | BEM1O1 | | | |
| Building the Entrepreneurial Mindset– CCi STEM | BEM1OP | | | |
| Building the Entrepreneurial Mindset- ESL | BEM1O8 | | | |
| Launching and Leading a Business | | BEP2O1 | | |
| Marketing: Goods, Services, Events | | | BMI3C1 | |
| Entrepreneurship: The Venture | | | BDI3C1 | |
| Financial Accounting | | | BAF3M1 | BAT4M1 |
| Accounting Essentials | | | BAI3E1 | |
| International Business Fundamentals | | | | BBB4M1 |
| Business Leadership: Management Fundamentals | | | | BOH4M1 |
| Financial Securities | | | | IDCFIN (IDC4U1) |
| Sports and Entertainment Marketing | | | | IDCSPO (IDC4U1) |
| COMPUTER SCIENCE | | | | |
| Introduction to Computer Science | | ICD2O1 | | |
| Computer Science - University | | | ICS3U1 | ICS4U1 |
| CANADIAN & WORLD STUDIES | | | | |
| Canadian Geography – De-streamed - English French Immersion/Extended French ESL | CGC1W1 CGC1W5 CGC1W8 | | | |
| Canadian History Since WW1 - Academic English French Immersion Extended French | | CHC2D1 CHC2D5 CHC2D4 | | |
| Canadian History Since WW1 – academic ESL | | CHC2D8 | | |
| Civics & Citizenship (0.5 Credit) packaged with Careers English ESL French Immersion Extended French | | CIVCAR (CHV2O1) CIVCA8 (CHV2O8) CIVCA5 (CHV2O5) CIVCA4 (CHV2O4) | | |

| Subject / Course Title | Grade 9 | Grade 10 | Grade 11 | Grade 12 |
|---|------------------|--|------------------|------------------|
| CANADIAN & WORLD STUDIES | | | | |
| Travel and Tourism: A Geographic Perspective | | | CGG301 | |
| World History – Ancient History | | | CHW3M1 | |
| World History- Modern History | | | | CHY4U1 |
| World Issues: A Geographic Analysis | | | | CGW4U1 |
| Canadian Law/ International Law | | | CLU3M1 | CLN4U1 |
| Analyzing Current Economic Issues | | | | CIA4U1 |
| SOCIAL SCIENCE AND THE HUMANITIES | | | | |
| Exploring Family Studies English | HIF101 | | | |
| Exploring Family Studies ESL | | HIF208 | | |
| Food and Nutrition | | HFN201 | | |
| Raising Healthy Children | | | HPC301 | |
| Understanding Fashion | | | HNC3C1 | |
| The World of Fashion | | | | HNB4M1 |
| Personal Life Management | | | | HIP4O1 |
| Nutrition and Health University College | | | | HFA4U1 HFA4C1 |
| Families in Canada | | | | HHS4U1 |
| World Religions: Beliefs in Daily Life | | | HRF301 | |
| Introduction to Anthropology, Psychology and Sociology University College | | | HSP3U1 HSP3C1 | |
| Equity and Social Justice: From Theory to Practice | | | | HSE4M1 |
| Challenge and Change in Society | | | | HSB4U1 |
| Philosophy: Questions and Theories | | | | HZT4U1 |
| CAREER STUDIES / CO-OPERATIVE EDUCATION /SPECIAL EDUCATION | | | | |
| Skills for Success in Secondary School | GLS101 | | | |
| Learning Strategies - SP. Ed. | GLE109 | GLE209 | GLE309 | GLE409 |
| Career Studies (0.5 Credit) packaged with Civics English ESL French Immersion Extended French | | CIVCAR (GLC201) CIVCA8 (GLC208) CIVCA5 (GLC205) CIVCA4 (GLC204) | | |
| Co-operative Education – 2 Credit –part day program (counts as 2 courses on course selection sheet) | | | COOP2 | COOP2 |
| Co-operative Education – 4 Credit –full day program (counts as 4 courses on course selection sheet) | | | COOP4 | COOP4 |
| ENGLISH | | | | |
| English Academic / University Academic – CCi STEM | ENL1W1 ENL1WP | ENG2D1 ENG2DP | NBE3U1 | ENG4U1 |
| English University – eLearning **NEW | | | NBE3UE | |
| English - College | | | NBE3C1 | ENG4C1 |
| English - Workplace | | | NBE3E1 | ENG4E1 |
| The Writer's Craft - University - College | | | | EWC4U1 EWC4C1 |
| O.S.S.L.T. - Literacy Course | | | | OLC4O1 |

| Subject / Course Title | Grade 9 | Grade 10 | Grade 11 | Grade 12 |
|--|--------------------------------------|--|--|--|
| E. S. L./LEAP | | | | |
| English as a Second Language | ESLA08 ESLBO8 ESLCO8 ESLDO8 | ESLA08 ESLBO8 ESLCO8 ESLDO8 ESLE08 | ESLA08 ESLBO8 ESLCO8 ESLDO8 ESLE08 | ESLA08 ESLBO8 ESLCO8 ESLDO8 ESLE08 |
| Exploring Family Studies – ESL Students | HIF208 | HIF208 | HIF208 | HIF208 |
| - Skills for Success in Secondary School - ESL Students | GLS108 | GLS108 | GLS108 | GLS108 |
| English Literacy Development (LEAP) - by permission only – see guidance counsellor | ELDA08 ELDBO8 ELDCO8 | ELDA08 ELDBO8 ELDCO8 | ELDA08 ELDBO8 ELDCO8 | ELDA08 ELDBO8 ELDCO8 |
| Skills for Success in Secondary School (LEAP) by permission only - see guidance counsellor | GLS10L GLS40L | GLS10L GLS40L | GLS10L GLS40L | GLS10L GLS40L |
| Mathematics (LEAP) by permission only - see guidance Counsellor | MAT1L8 MAT2L8 | MAT1L8 MAT2L8 | MAT1L8 MAT2L8 | MAT1L8 MAT2L8 |
| Science (LEAP) by permission only - see guidance counsellor | SNC1L8 SNC2L8 | SNC1L8 SNC2L8 | SNC1L8 SNC2L8 | SNC1L8 SNC2L8 |
| FRENCH/SPANISH | | | | |
| French - Academic/University | FSF1D1 | FSF2D1 | FSF3U1 | FSF4U1 |
| - Beginners/Introductory | FSF1O1 | FSF1O1 | FSF1O1 | FSF1O1 |
| French Immersion | FIF1D5 | FIF2D5 | FIF3U5 | FIF4U5 |
| Extended French | FIF1D5 | FEF2D4 | FEF3U4 | FEF4U4 |
| Spanish | | LWSBD1 | LWSCU1 | LWSDU1 |
| HEALTH and PHYSICAL EDUCATION | | | | |
| Physical Education - males | PPL10M | PPL20M | PPL30M | PPL40M |
| Physical Education - females | PPL10F | PPL20F | PPL30F | PPL40F |
| Physical Education - all gendered | PPL101 | PPL201 | | |
| Education Physique & Hygiene education – French immersion - female | PPL10G | PPL20G | | |
| Extended French - female | PPL10G | PPL20J | | |
| French Immersion - male | PPL10Q | PPL20Q | | |
| Extended French - male | PPL10Q | PPL20U | | |
| French Immersion – all gendered | PPL10K | PPL20K | PPL30K | PPL40K |
| Extended French – all gendered | PPL10K | PPL20L | PPL30L | PPL40L |
| Personal Fitness female | | | PAF30F | PAF40F |
| male | | | PAF30M | PAF40M |
| all gendered | | | PAF301 | PAF401 |
| Introductory Kinesiology | | | | PSK4U1 |
| SEE U of T SCARBOROUGH PROGRAM | | | | |
| SEE UTSC is a collaboration between the UTSC and the TDSB. It is a way for students to immerse themselves in university studies, leadership development, and campus life in Grade 11 and 12. It is a 2-year program, so the expectation is that all students who are currently enrolled in SEE UTSC will select SEEUTSC12 during course selection. Please note SEEUTSC11 is a prerequisite for SEEUTSC12. Students are not able to join the program in year 2 (SEEUTSC12) without completing the first year (SEEUTSC11). | | | SEEUTSC11 | SEEUTSC12 |

| Subject / Course Title | Grade 9 | Grade 10 | Grade 11 | Grade 12 |
|---|----------------------------|----------------------------|------------------|------------------|
| MATHEMATICS | | | | |
| Foundational Mathematics -English - French Immersion | MTH1W1 MTH1W5 | | | |
| Mathematics - Academic / University | | MPM2D1 | MCR3U1 | |
| Mathematics - Academic - Immersion French | | MPM2D5 | | |
| Mixed Math - College / University | | | MCF3M1 | |
| Mathematics - College | | | MBF3C1 | MAP4C1 |
| Mathematics - Workplace | | | MEL3E1 | |
| Data Management - University | | | | MDM4U1 |
| Advanced Functions - University | | | | MHF4U1 |
| Calculus & Vectors - University | | | | MCV4U1 |
| SCIENCE | | | | |
| Science - Academic English French Immersion/Extended French CCi STEM | SNC1W1 SNC1W5 SNC1WP | SNC2D1 SNC2D5 SNC2DP | | |
| Biology - University | | | SBI3U1 | SBI4U1 |
| Chemistry - University | | | SCH3U1 | SCH4U1 |
| Physics - University | | | SPH3U1 | SPH4U1 |
| Earth and Space Science - University | | | | SES4U1 |
| Biology - College | | | SBI3C1 | |
| Chemistry - College | | | | SCH4C1 |
| TECHNOLOGICAL EDUCATION | | | | |
| Technology and the Skilled Trades Open | TAS1O1 | | | |
| Technological Design Open College/University | | TDJ2O1 | TDJ3M1 | TDJ4M1 |
| Technological Design Architectural Design College/University | | | TDA3M1 | TDA4M1 |
| Construction Engineering Technology – Civil Engineering College | | | TCY3C1 | TCY4C1 |
| Construction Technology – Electrical Workplace | | | TCE3E1 | TCE4E1 |
| Construction Technology Woodworking Open College Workplace | | TCJ2O1 | TCJ3C1 TCJ3E1 | TCJ4C1 TCJ4E1 |
| Custom Woodworking – Workplace | | | TWJ3E1 | TWJ4E1 |
| Transportation Technology Open College | | TTJ2O1 | TTJ3C1 | TTJ4C1 |
| Communications Technology Open College/University | | TGJ2O1 | TGJ3M1 | TGJ4M1 |
| Communication Technology – Photography & Digital Media College/ University | | | TGP3M1 | TGP4M1 |