

GUIDANCE COURSES

Prerequisite Chart for Guidance and Career Education

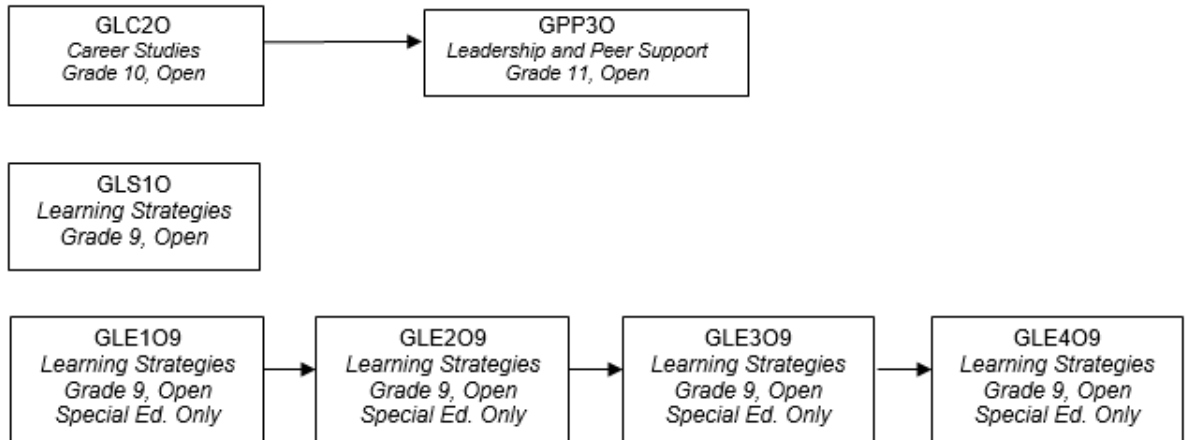

Career Studies, Grade 10, Open

(GLC20)

This course teaches students how to develop and achieve personal goals for future learning, work, and community involvement. Students will assess their interests, skills, and characteristics and investigate current economic and workplace trends, work opportunities, and ways to search for work. The course explores postsecondary learning and career options, prepares students for managing work and life transitions, and helps students focus on their goals through the development of a career plan.

Prerequisite: None

Learning Strategies 1: Skills for Success in Secondary School, Grade 9, Open

(GLE10)

This course focuses on learning strategies to help students become better, more independent learners. Students will learn how to develop and apply literacy and numeracy skills, personal management skills, and interpersonal and teamwork skills to improve their learning and achievement in school, the workplace, and the community. The course helps students build confidence and motivation to pursue opportunities for success in secondary school and beyond.

Prerequisite: None (for students with an IEP)

Learning Strategies 1: Skills for Success in Secondary School, Grade 10, Open

(GLE20)

This course focuses on learning strategies to help students become better, more independent learners. Students will learn how to develop and apply literacy and numeracy skills, personal management skills, and interpersonal and teamwork skills to improve their learning and achievement in school, the workplace, and the community. The course helps students build confidence and motivation to pursue opportunities for success in secondary school and beyond.

Prerequisite: None (for students with an IEP)

Advanced Learning Strategies: Skills for Success After Secondary School, Grade 11, Open (GLE30)

This course improves students' learning and personal-management skills, preparing them to make successful transitions to work, training, and/or postsecondary education destinations. Students will assess their learning abilities and use literacy, numeracy, and research skills and personal-management techniques to maximize their learning. Students will investigate trends and resources to support their postsecondary employment, training, and/or education choices and develop a plan to help them meet their learning and career goals.

Prerequisite: None (for students with an IEP)

Advanced Learning Strategies: Skills for Success After Secondary School, Grade 12, Open (GLE40)

This course improves students' learning and personal-management skills, preparing them to make successful transitions to work, training, and/or postsecondary education destinations. Students will assess their learning abilities and use literacy, numeracy, and research skills and personal-management techniques to maximize their learning. Students will investigate trends and resources to support their postsecondary employment, training, and/or education choices and develop a plan to help them meet their learning and career goals.

Prerequisite: None (for students with an IEP)

Learning Strategies 1: Skills for Success in Secondary School, Grade 9, Open (GLS10)

This course focuses on learning strategies to help students become better, more independent learners. Students will learn how to develop and apply literacy and numeracy skills, personal management skills, and interpersonal and teamwork skills to improve their learning and achievement in school, the workplace, and the community. The course helps students build confidence and motivation to pursue opportunities for success in secondary school and beyond.

Prerequisite: None

Leadership and Peer Support, Grade 11, Open (GPP30)

This course prepares students to act in leadership and peer support roles. They will design and implement a plan for contributing to their school and/or community; develop skills in communication, interpersonal relations, teamwork, and conflict management; and apply those skills in leadership and/or peer support roles – for example, as a student council member or a peer tutor. Students will examine group dynamics and learn the value of diversity within groups and communities.

Prerequisite: Career Studies, Grade 10, Open